

Service Manual

ECLIPSE/ **ECLIPSE** *SPYDER*

Volume 1

Chassis & Body

*Includes Engine & Transaxle
Overhaul*

FOREWORD

This Service Manual has been prepared with the latest service information available at the time of publication. It is subdivided into various group categories and each section contains diagnostic, disassembly, repair, and installation procedures along with complete specifications and tightening references. Use of this manual will aid in properly performing any servicing necessary to maintain or restore the high levels of performance and reliability designed into these outstanding vehicles.



Mitsubishi Motors Corporation reserves the right to make changes in design or to make additions to or improvements in its products without imposing any obligations upon itself to install them on its products previously manufactured.

GROUP INDEX

... 00109000607

General	00
Engine	11
Engine Lubrication	12
Fuel	13
Engine Cooling	14
Intake and Exhaust,	15
Engine and Emission Control, ...	17
Clutch	21
Manual Transaxle	22
Automatic Transaxle	23
Propeller Shaft	25
Front Axle	26
Rear Axle	27
Wheel and Tire	31
Power Plant Mount	32
Front Suspension	33
Rear Suspension	34
Service Brakes	35
Parking Brakes	36
Steering	37
Body	42
Exterior	51
Interior and Supplemental Restraint System (SRS)	52
Heater, Air Conditioning and Ventilation	55
Alphabetical Index	

NOTE: Electrical system information is contained in Volume 2 "Electrical" of this paired Service Manual.

WARNINGS REGARDING SERVICING OF SUPPLEMENTAL RESTRAINT SYSTEM (SRS) EQUIPPED VEHICLES

WARNING!

- (1) Improper service or maintenance of any component of the SRS, or any **SRS-related** component, can lead to personal injury or death to service personnel **(from inadvertent firing of the air bag)** or to the driver and passenger (from rendering the SRS inoperative).
- (2) If it is possible that the SRS components are **subjected to heat over 93°C (200°F)** in baking or in drying after painting, remove the SRS components (air bag module, **SRS-ECU**) beforehand.
- (3) Service or maintenance of any SRS component or SRS-related component **must** be performed only at an authorized MITSUBISHI dealer.
- (4) MITSUBISHI dealer personnel must thoroughly review this manual, and **especially** its **GROUP 52B** – Supplemental Restraint System (SRS), before beginning any service or maintenance of any component of the SRS or any SRS-related component.

NOTE

Section titles with the asterisks (*) in the table of contents in each group indicate operations requiring **warnings**.

GENERAL

CONTENTS

00109000171

GENERAL DATA AND SPECIFICATIONS . . .	28	Evaporative Emission Control System	39
HOW TO USE THIS MANUAL	3	Exhaust System	54
Explanation of Manual Contents	4	Fuel Hoses	38
Model Indications	3	Fuel System	38
Maintenance, Repair and Servicing Explanations.	3	Ignition Cables	40
Special Tool Note	3	Manual Transaxle Oil	44
Terms Definition	3	Rear Axle Oil	50
Tightening Torque Indication	3	Rear Drum Brake Linings and Rear Wheel Cylinders	49
HOW TO USE TROUBLESHOOTING/ INSPECTION SERVICE POINTS	6	Spark Plugs	40
Connector Inspection Service Points	10	SRS System	51
Connector Measurement Service Points	9	Timing Belt	40
How to Cope with Intermittent Malfunctions	11	Transfer Oil	48
How to Use the Inspection Procedures	8	PRECAUTIONS BEFORE SERVICE	20
Inspection Service Points for a Blown Fuse	12	RECOMMENDED LUBRICANTS AND LUBRICANT CAPACITIES TABLE	34
Troubleshooting Contents	6	SCHEDULED MAINTENANCE TABLE	37
LUBRICATION AND MAINTENANCE	33	SPECIAL HANDLING INSTRUCTIONS FOR AWD MODELS	26
MAIN SEALANT AND ADHESIVE TABLE	55	TIGHTENING TORQUE	32
MAINTENANCE SERVICE	38	TOWING AND HOISTING	22
Air Cleaner Element	39	VEHICLE IDENTIFICATION	13
Automatic Transaxle Fluid	45	Engine Model Stamping	15
Ball Joint and Steering Linkage Seals	50	Theft Protection	18
Brake Hoses	50	Vehicle Identification Code Chart Plate	13
Disc Brake Pads	49	Vehicle Identification Number List	14
Drive Belt (For Generator, Water Pump, Power Steering Pump)	40	Vehicle Identification Number Location	13
Drive Shaft Boots	50	Vehicle Information Code Plate.	15
Engine Coolant	48	Vehicle Safety Certification Label	15
Engine Oil	42		
Engine Oil Filter	43		

234

*

11/23/00

Handwritten notes in the right margin, including various numbers and symbols.

DATE TIME GROUP

HOW TO USE THIS MANUAL

00100010142

MAINTENANCE, REPAIR AND SERVICING EXPLANATIONS

This manual provides explanations, etc. concerning procedures for the inspection, maintenance, repair and servicing of the subject model. Unless otherwise specified, each service procedure covers all models. Procedures covering specific models are identified by the model codes, or similar designation (engine type, transaxle type, etc.). A description of these designations is covered in this manual under "VEHICLE IDENTIFICATION".

ON-VEHICLE SERVICE

"On-vehicle Service" are procedures for performing inspections and adjustments of particularly important locations with regard to the construction and for maintenance and servicing, but other inspections (for looseness, play, cracking, damage, etc.) must also be performed.

SERVICE PROCEDURES

The service steps are arranged in numerical order and attention must to be paid in performing vehicle service are described in detail in SERVICE POINTS.

TERMS DEFINITION

STANDARD VALUE

Indicates the value used as the standard for judging the quality of a part or assembly on inspection or the value to which the part or assembly is corrected and adjusted. It is given by tolerance.

LIMIT

Indicates a maximum or minimum value, the part or assembly should be kept within, in order to be

functional. This value is established outside the standard value range.

REFERENCE VALUE

Indicates the adjustment value prior to starting the work (presented in order to facilitate assembly and adjustment procedures, and so they can be completed in a shorter time).

CAUTION

Indicates the presentation of information particularly vital to the worker during the performance of maintenance and servicing procedures in order to avoid the possibility of injury to the worker, or damage to component parts, or a reduction of component or vehicle function or performance, etc..

TIGHTENING TORQUE INDICATION

The tightening torque shown in this manual is a basic value with a tolerance of $\pm 10\%$ except the following cases when the upper. and **lower limits** of tightening torque are given.

- (1) The tolerance of the 'basic value **is within $\pm 10\%$** .
- (2) Special bolts or, the 'like are **in use**.
- (3) Special tightening methods are used.

SPECIAL TOOL NOTE

When the MMC special tool is described, please refer to the special tool **cross reference chart, which** is located at the beginning of each group, for a cross reference from the **MMC special** tool, number to the special tool number that **is** available in your market.

MODEL INDICATIONS

The following abbreviations are used in this manual for classification of model types.

M/T : Indicates the manual transaxle, or models equipped with the manual transaxle.

A/T : Indicates the automatic transaxle, or models equipped with the automatic transaxle.

MFI: Indicates the **multiport** fuel injection, or engines equipped with the **multiport** fuel injection.

Turbo: Indicates the engine with turbocharger, or models equipped **with** such an **engine**.

Non-turbo: Indicates the engine without turbocharger, or models equipped with, such an engine.

FWD: Indicates the front wheel drive vehicles.

AWD: Indicates the all wheel drive vehicles.

ABS: Indicates the anti-lock braking system or models equipped with the **anti-lock** braking **system**.

EXPLANATION OF MANUAL CONTENTS

Indicates procedures to be performed before the work in that section is started, and procedures to be performed after the work in that section is finished.

Component Diagram

A diagram of the component parts is provided near the front of each section in order to give the reader a better understanding of the installed condition of component parts.

Indicates (by symbols) where lubrication is necessary.

Maintenance and Servicing Procedures

The numbers provided within the diagram indicate the sequence for maintenance and servicing procedures.

- **Removal steps :**

The part designation number corresponds to the number in the illustration to indicate removal steps.

- **Disassembly steps :**

The part designation number corresponds to the number in the illustration to indicate disassembly steps.

- **Installation steps :**

Specified in case installation is impossible in reverse order of removal steps. Omitted if installation is possible in reverse order of removal steps.

- **Reassembly steps :**

Specified in case reassembly is impossible in reverse order of disassembly steps. Omitted if reassembly is possible in reverse order of disassembly steps.

Classifications of Major Maintenance / Service points

When there are major points relative to maintenance and servicing procedures (such as essential maintenance and service points, maintenance and service standard values, information regarding the use of special tools, etc.), these are arranged together as major maintenance and service points and explained in detail.

◀A▶ : Indicates that there are essential points for removal or disassembly.

▶A◀ : Indicates that there are essential points for installation or reassembly.

Symbols for Lubrication, Sealants and Adhesives

Information concerning the locations for lubrication and for application of sealants and adhesives is provided, by using symbols, in the diagram of component parts or on the page following the component parts page, and explained.

 : Grease
(multipurpose grease unless there is a brand or type specified)

 : Sealant or adhesive

 : Brake fluid or automatic transmission fluid

 : Engine oil, gear oil or air conditioning compressor oil

 : Adhesive tape or butyl rubber tape

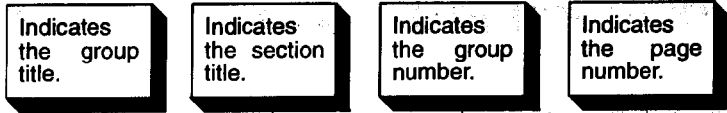

1 STEERING - Power Steering Gear Box 37A-23

POWER STEERING GEAR BOX
REMOVAL AND INSTALLATION

Pre-removal Operation
 • Power Steering Fluid Draining (Refer to P37A-15.)
 • Stabilizer Bar Removal (Refer to GROUP 33A - Stabilizer Bar)

Denotes tightening torque. If there is no indication of tightening torque refer to TIGHTENING TABLE.

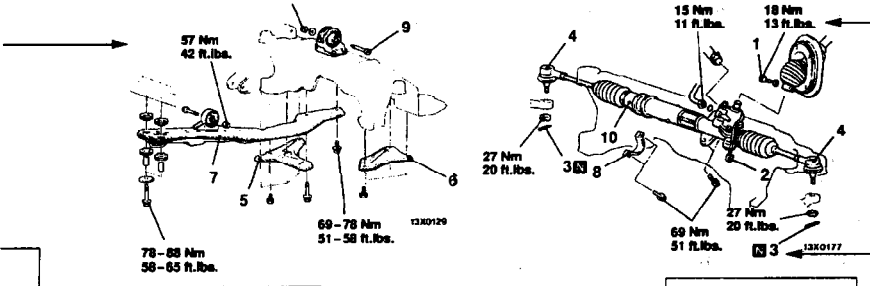

Denotes non-reusable part.

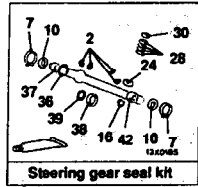
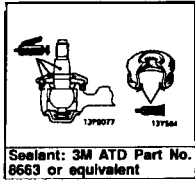

Repair kit or set parts are shown. (Only very frequently used parts are shown.)

- Removal steps**
1. Joint assembly and gear box connecting bolt
 2. Solenoid valve connector <Vehicles with EPS>
 3. Cotter pin
 4. Connection for tie-rod end and knuckle
 5. Stay (L.H.)
 6. Stay (R.H.)
 7. Center member assembly
 8. Clamp
 9. Bolt
 10. Gear box assembly

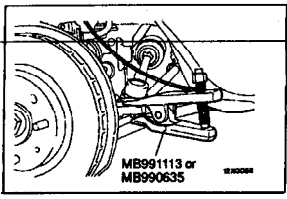

REMOVAL SERVICE POINTS
TIE-ROD END DISCONNECTION

- Caution**
1. Be sure to tie the cord of the special tool to the nearby part.
 2. Loosen the nut but do not remove it.

Operating procedures, cautions, etc. on removal, installation, disassembly and reassembly are described.

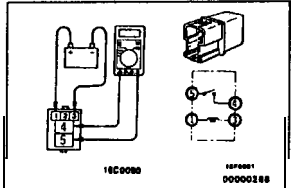

FOG LIGHT RELAY CONTINUITY CHECK

Battery voltage	Terminal			
	1	3	4	5
Power is not supplied	o - - a			
Power is supplied	⊕ - - ⊖		⊖ - - ⊕	

○-○ indicates that there is continuity between the terminals.
 ⊕-⊖ indicates terminals to which battery voltage is applied.

37A-28 STEERING - Power Steering Gear Box

LUBRICATION AND SEALING POINTS
<Conventional power steering gear box>

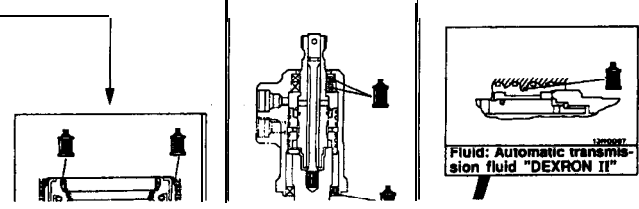

Fluid: Automatic transmission fluid "DEXRON II"

The title of the page (following the page on which the diagram of Component parts is presented) indicating the locations of lubrication and sealing procedures.

HOW TO USE TROUBLESHOOTING/INSPECTION SERVICE POINTS

00100020060

Troubleshooting of electronic control systems for which the scan tool **can be used follows** the basic outline described below. Furthermore, even in systems for which the scan tool cannot be used, part of these systems still follow this outline.

TRUBLESHOOTING CONTENTS

1. STANDARD FLOW OF DIAGNOSTIC TROUBLESHOOTING

The main procedures for diagnostic troubleshooting are shown.

2. SYSTEM OPERATION AND SYMPTOM VERIFICATION TESTS

If verification of the trouble symptoms is difficult, procedures for checking operation and verifying trouble symptoms are shown.

3. DIAGNOSTIC FUNCTION

The following diagnostic functions are shown.

- Method of reading diagnostic trouble codes
- Method of erasing diagnostic trouble codes
- Input inspection service points

4. INSPECTION CHART FOR DIAGNOSTIC TROUBLE CODES

5. INSPECTION PROCEDURE FOR DIAGNOSTIC TROUBLE CODES

Indicates the inspection procedures corresponding to each diagnostic trouble code. (Refer to the next page on how to use the inspection procedures.)

6. INSPECTION CHART FOR TROUBLE SYMPTOMS

If there are trouble symptoms, even though the scan tool displays no diagnostic **trouble code**, inspection procedures for each trouble symptom will be found by means of this chart.

7. INSPECTION PROCEDURE FOR TROUBLE SYMPTOMS

Indicates the inspection procedures corresponding to each trouble symptoms **classified in** the Inspection Chart for Trouble Symptoms. (Refer to the next page on how to use the inspection procedures.)

8. DATA LIST REFERENCE TABLE

Inspection items and normal judgement values have been provided in this chart as reference **information**.

9. CHECK AT ECU TERMINALS

Terminal numbers for the ECU connectors, inspection items and standard values have been provided in this chart as reference information.

Terminal Voltage Checks

1. Connect a needle-nosed wire probe or paper clip to a voltmeter probe.
2. Insert the needle-nosed wire probe into each of the ECU connector **terminals** from the wire side, and measure the voltage while referring to the check chart.

NOTE

1. Measure voltage with the ECU connectors connected.
2. You may find it convenient to pull out the ECU to make it easier to reach the connector terminals.
3. Checks don't have to be carried out in the order given in the chart.

Caution

Short-circuiting the positive (+) probe between a connector terminal and ground could damage the vehicle wiring, the sensor, the ECU, or all three.

Use care to prevent this !

3. If voltage readings differ from Normal Condition values, **check** related **sensors**, actuators, and wiring, then replace or repair.

4. After repair or replacement, recheck **with** the voltmeter to confirm **that** the repair **has corrected** the problem.

Terminal Resistance and Continuity Checks

1. Turn the ignition switch to off.
2. Disconnect the ECU connector.
3. Measure the resistance and check for continuity between the terminals of the ECU **harness-side** connector while referring to the check chart.

NOTE

Checks don't have to be carried out in the order given in the chart.

Caution

If resistance and continuity checks are performed on the wrong terminals, damage to the vehicle wiring, sensors, ECU, and/or ohmmeter may occur.

Use care to prevent this!

4. If the ohmmeter shows any deviation from the Normal Condition value, check the corresponding sensor, actuator and related electrical wiring, then repair or replace.
5. After repair or replacement, recheck with the ohmmeter to confirm that the repair **has corrected** the problem.

10. INSPECTION PROCEDURES USING AN OSCILLOSCOPE

When there are inspection procedures using an oscilloscope, these are listed here.

HOW TO USE THE INSPECTION PROCEDURES

The causes of a high frequency of problems occurring in electronic circuitry are generally **the connectors, components, the ECU and the harnesses between connectors**, in that **order**. These **inspection procedures** follow this order, and they first try to discover a problem with a connector or a **defective component**.

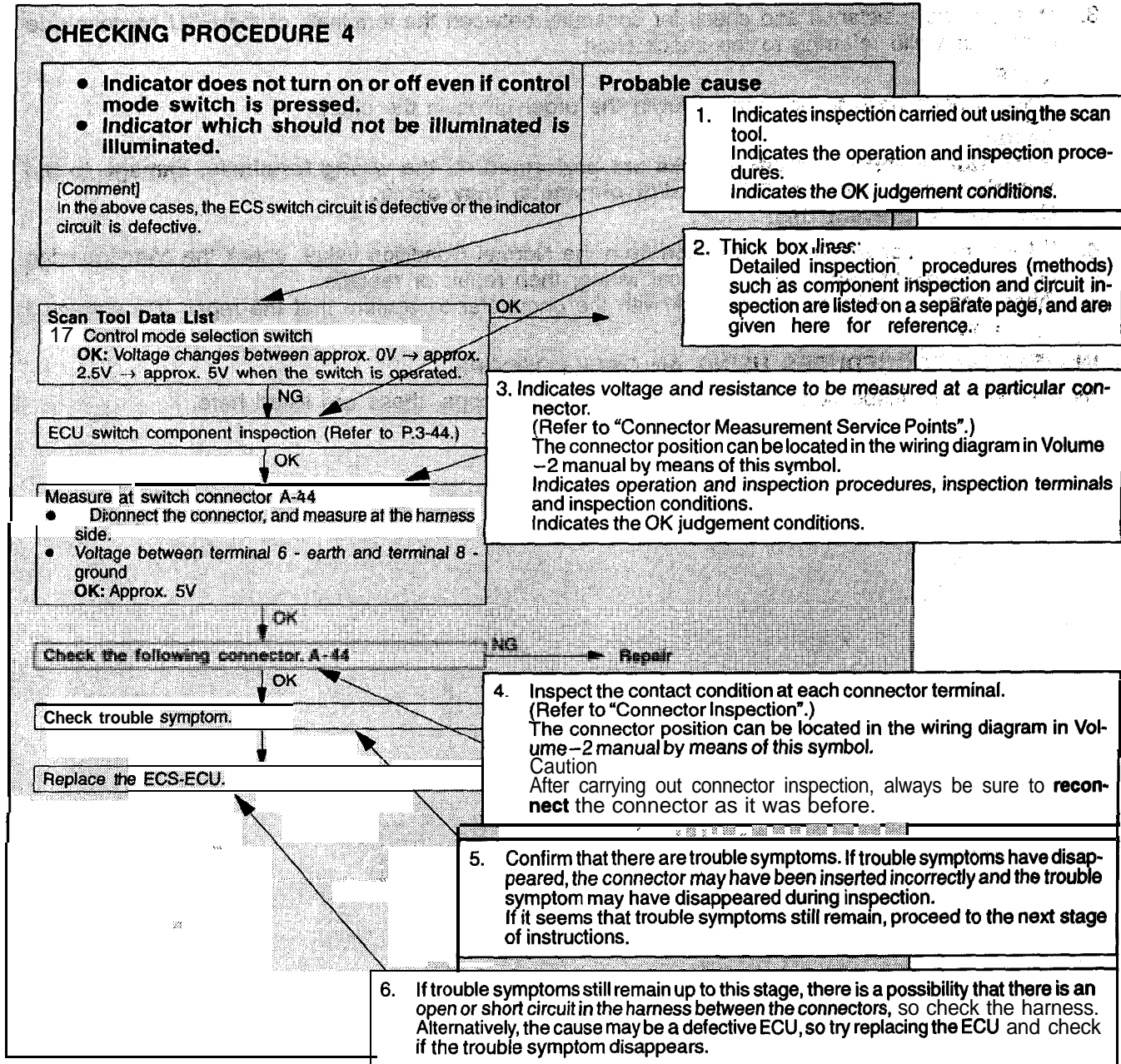

HARNESS INSPECTION

Check for an open or short circuit in the harness between the terminals which were defective according to the connector measurements. Carry out this inspection while referring to Volume 2 Electrical manual. Here, "Check harness between power supply and terminal xx" also includes checking for blown fuses. For inspection service points when there is a blown fuse, refer to "Inspection Service Points for a Blown Fuse".

MEASURES TO TAKE AFTER REPLACING THE ECU

If the trouble symptoms have not disappeared even after replacing the ECU, repeat the inspection procedure from the beginning.

CONNECTOR MEASUREMENT SERVICE POINTS

Turn the ignition switch to **OFF** when connecting and disconnecting the connectors, and turn the ignition switch to **ON** when measuring if there are no instructions to the contrary.

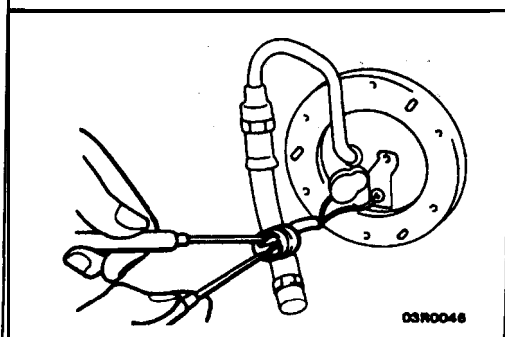
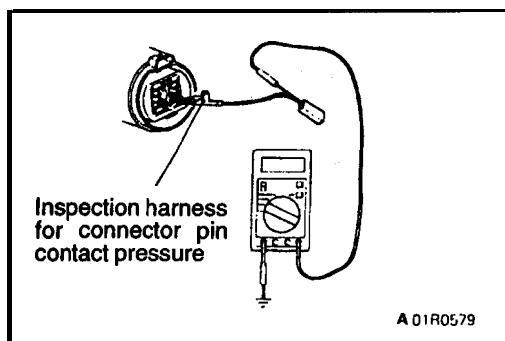
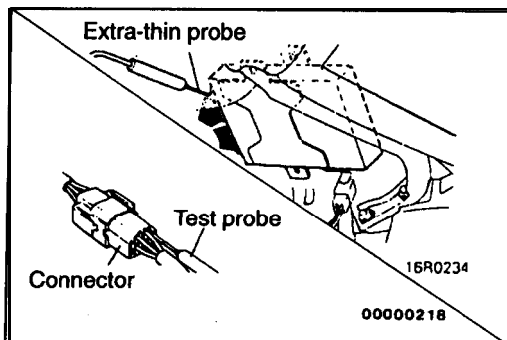
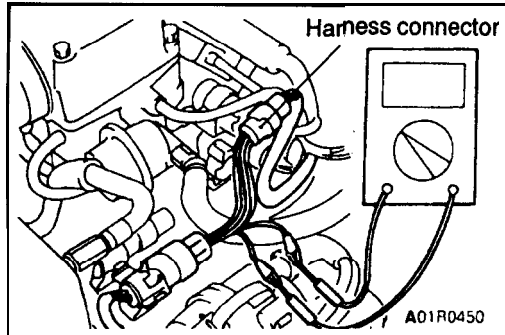
**IF INSPECTING WITH THE CONNECTOR CONNECTED (WITH CIRCUIT IN A CONDITION OF CONTINUITY)****Waterproof Connectors**

Be sure to use the special tool (harness connector). Never insert a test probe from the harness side, because to do so will reduce the waterproof performance and result in corrosion.

Ordinary (non-waterproof) Connectors

Check by inserting the test probe from the harness side. Note that if the connector (control unit, etc.) is too small to permit insertion of the test probe, it should not be forced; use a special tool (the extra-thin probe in the harness set for checking) for this purpose.

IF INSPECTING WITH THE CONNECTOR DISCONNECTED, <When Inspecting a Female Pin>

Use the special tool (inspection harness for connector pin contact pressure in the harness set, for inspection). The inspection harness for connector pin contact pressure should be used. The test probe **should never** be forcibly inserted, as it may cause a defective contact.

<When Inspecting a Male Pin>

Touch the pin directly with the test bar.

Caution

At this time, be careful not to short the connector pins with the test probes. To do so may damage the circuits inside the ECU.

Connector disconnected or improperly connected

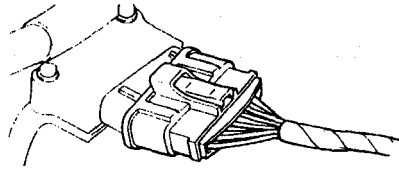

1650256

Defective connector contact

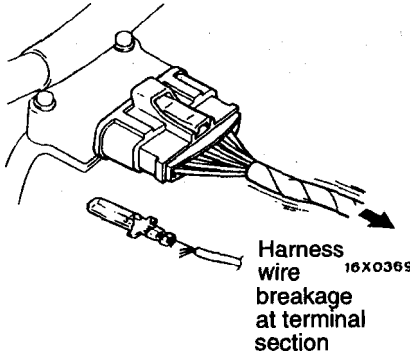

Low contact pressure

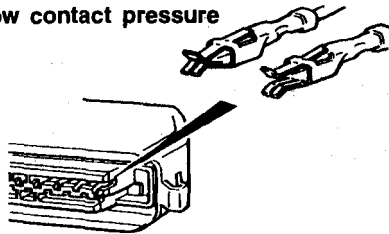

16'30254
00000219

CONNECTOR INSPECTION SERVICE POINTS

VISUAL INSPECTION

- Connector is disconnected or improperly connected
- Connector pins are pulled out
- Harness wire breakage due to harness tension at terminal section
- Low contact pressure between male and female terminals
- Low connection pressure due to rusted terminals or foreign matter lodged in terminals

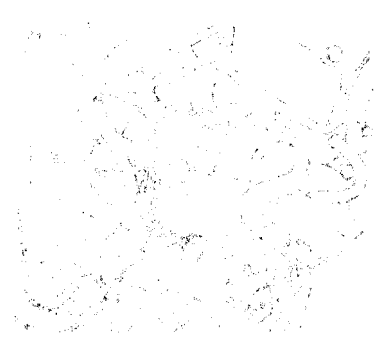

CONNECTOR PIN INSPECTION

If the connector pin stopper is damaged, the terminal connections (male and female pins) will not be perfect even when the connector body is connected, because the pins may pull out of the back side of the connector. Therefore, gently pull the wires one by one to make sure that no pins pull out of the connector.

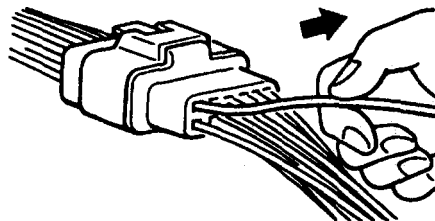

16R1317

CONNECTOR ENGAGEMENT INSPECTION

Use the special tool (connector pin connection pressure inspection harness of the inspection harness set) to inspect the engagement of the male pins and female pins. [Pin drawing force : 1 N (.2 lbs.) or more]

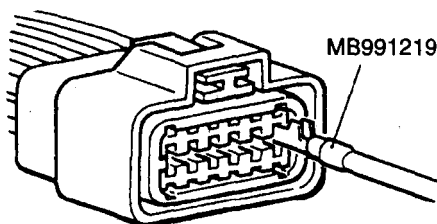

MB991219

A16R1318

HOW TO COPE WITH INTERMITTENT MALFUNCTIONS

Most intermittent malfunctions occur under certain conditions. If those conditions can be identified, the cause will be easier to find.

TO COPE WITH INTERMITTENT MALFUNCTION;

1. Ask the customer about the malfunction

Ask what it feels like, what it sounds like, etc. Then ask about driving conditions; weather, frequency of occurrence, and so on.

2. Determine the conditions from the customer's responses

Typically, almost all intermittent malfunctions occur from conditions like vibration, temperature and/or moisture change, poor connections. From the customer's replies, it should be reasoned which condition is influenced.

3. Use simulation test

In the cases of vibration or poor connections, use the simulation tests below to attempt to

duplicate the customer's complaint. Determine the most likely circuit(s) and perform the simulation tests on the connectors and parts of that circuit(s). Be sure to use the inspection procedures provided for diagnostic trouble codes and trouble symptoms. For temperature and/or moisture conditions related intermittent malfunctions, using common sense, try to change the conditions of the suspected circuit components, then use the simulation tests below,

4. Verify the intermittent malfunction is eliminated

Repair the malfunctioning part and try to duplicate the condition(s) again to verify the intermittent malfunction has been eliminated.

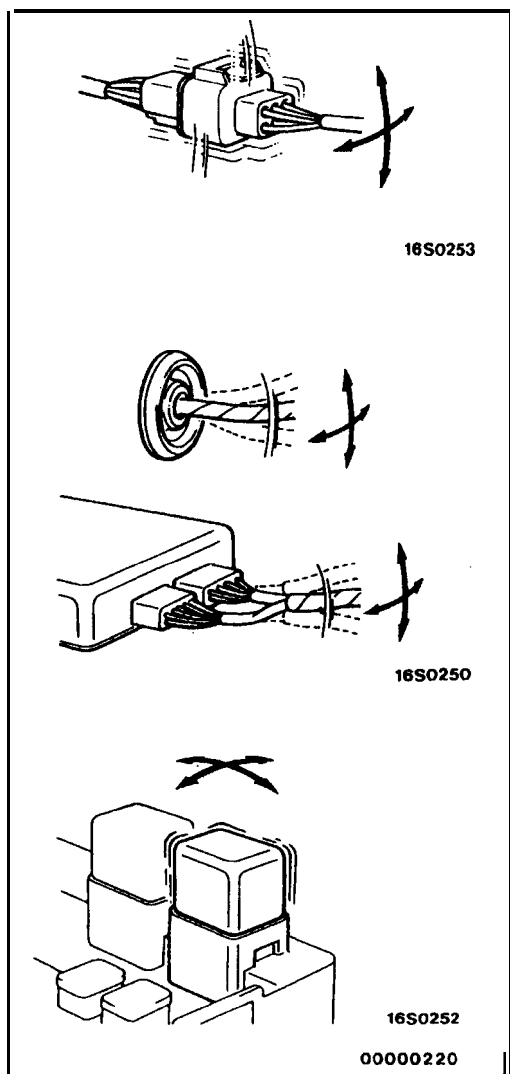

SIMULATION TESTS

For these simulation tests, shake, then gently bend, pull, and twist the wiring of each of these examples to duplicate the intermittent malfunction.

- Shake the connector up-and-down, and right-and-left.
- Shake the wiring harness up-and-down, and right-and-left.
- Vibrate the part or sensor.

NOTE

In case of difficulty in finding the cause of the intermittent malfunction, the data recorder function in the scan tool is effective.

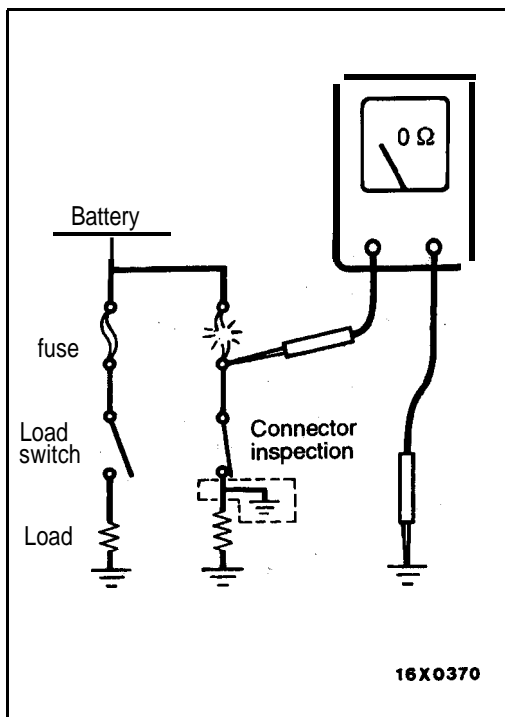

INSPECTION SERVICE POINTS FOR A BLOWN FUSE

Remove the fuse and measure the resistance **between** the load side of the fuse and ground. Set the **switches** of all circuits which are connected **to this fuse to a condition of continuity**. If the resistance is almost **0 Ω** at this time, there is a short somewhere **between these switches and the load**. If the resistance is not 0 Ω, there is no short **at the present time**, but a momentary short has **probably caused the fuse to blow**.

The main causes of a short **circuit are the following**.

- Harness being clamped by the vehicle-body
- Damage to the **outer casing** of the **harness** due to wear or heat
- Water getting into the connector or **circuitry**,
- Human error (mistakenly shorting a circuit, etc.)

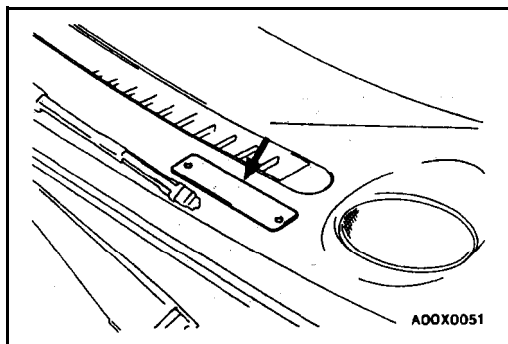

VEHICLE IDENTIFICATION

00100040189

VEHICLE IDENTIFICATION NUMBER LOCATION

The vehicle identification number (V.I.N.) is located on a plate attached to the left top side of the instrument panel.

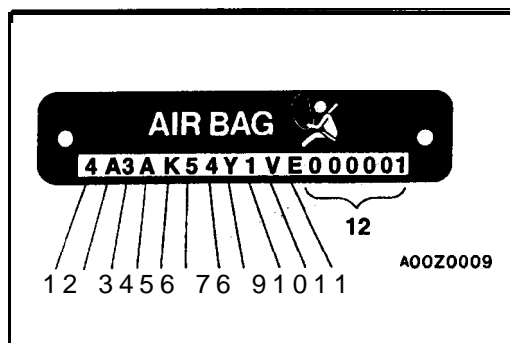

VEHICLE IDENTIFICATION CODE CHART PLATE

All vehicle identification numbers contain 17 digits. The vehicle number is a code which tells country, make, vehicle type, etc.

No	Items	Contents
1	Country	4: USA
2	Make	A: Mitsubishi
3	Vehicle type	3: Passenger car
4	Others	A: Drive and passenger air bags
5	Line	K: ECLIPSE <FWD>
		L: ECLIPSE <AWD>
		X: ECLIPSE SPYDER
6	Price class	2: Low
		3: Medium
		4: High
		5: Premium
7	Body	4: 3-door hatchback
		5: 2-door "convertible"
8	Engine	Y: 2.0dm ³ (122.0cu.in.) [DOHC-MFI]
		F: 2.0dm ³ (122.0cu.in.) [DOHC-MFI-Turbo]
		G: 2.4dm ³ (146.5cu.in.) [SOHC-MFI]
9	Check digits*	1 2 3 4 5 6 7 8 9 X
10	Model year	V: 1997
11	Plant	E: Mitsubishi Motor Manufacturing of America, Inc.
12	Serial number	000001 to 999999

NOTE

* "Check digit" means a single number or letter X used to verify the accuracy of transcription of vehicle identification number.

VEHICLE IDENTIFICATION NUMBER LIST

VEHICLES FOR FEDERAL

V.I.N. (except sequence number)	Brand	Engine displacement	Model code
4A3AK24Y_VE	Mitsubishi Eclipse <FWD>	2.0 dm ³ (122.0 cu.in.) [DOHC-MFI (420A)]	D31AMNSML4M D31AMRSML4M
4A3AK34Y_VE			D31AMNJML4M D31AMRJML4M
4A3AK44Y_VE			D31AMNHML4M D31AMRHML4M
4A3AK54F_VE			2.0 dm ³ (122.0 cu.in.) [DOHC-MFI-Turbo (4G63)]
4A3AL54F_VE	Mitsubishi Eclipse <AWD>	D33AMNGFL4M D33AMRGFL4M	
4A3AX55F_VE	Mitsubishi Eclipse Spyder	2.0 dm ³ (122.0 cu.in.) [DOHC-MFI-Turbo (4G63)]	D38ABNGFL4M D38ABRGFL4M
4A3AX35G_VE			2.4 dm ³ (146.5 cu.in.) [SOHC-MFI (4G64)]

VEHICLES FOR CALIFORNIA

V.I.N. (except sequence number)	Brand	Engine displacement	Model code
4A3AK24Y_VE	Mitsubishi Eclipse <FWD>	2.0 dm ³ (122.0 cu.in.) [DOHC-MFI (420A)]	D31AMNSML9M D31AMRSML9M
4A3AK34Y_VE			D31AMNJML9M D31AMRJML9M
4A3AK44Y_VE			D31AMNHML9M D31AMRHML9M
4A3AK54F_VE			2.0 dm ³ (122.0 cu.in.) [DOHC-MFI-Turbo (4G63)]
4A3AL54F_VE	Mitsubishi Eclipse <AWD>	D33AMNGFL9M D33AMRGFL9M	
4A3AX55F_VE	Mitsubishi Eclipse Spyder	2.0 dm ³ (122.0 cu.in.) [DOHC-MFI-Turbo (4G63)]	D38ABNGFL9M D38ABRGFL9M
4A3AX35G_VE			2.4 dm ³ (146.5 cu.in.) [SOHC-MFI (4G64)]

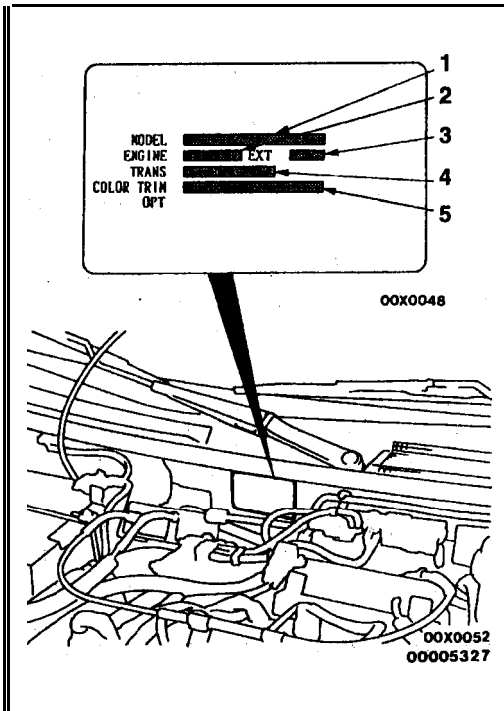

VEHICLE INFORMATION CODE PLATE

Vehicle information code plate is riveted onto the bulkhead in the engine compartment.

The plate shows model code, engine model, transaxle model, and body color code.

No.	Item	Contents	
1	MODEL	D32AM	D32AM: Vehicle model
			RGFL4E: Model series
2	ENGINE	4G63	Engine model
3	EXT	CA6A	Exterior code
4	TRANS	F4A33	Transaxle code
5	COLOR TRIM OPT	R25 87V 03V	R25: Body color code
			87V: Interior code
			03V: Equipment code

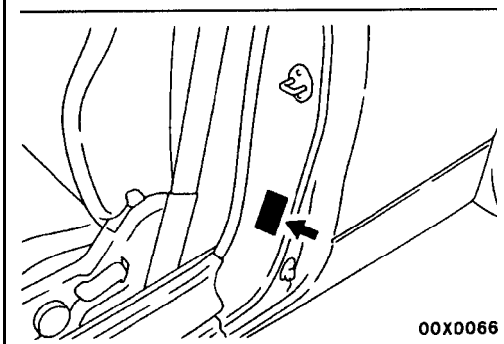

VEHICLE SAFETY CERTIFICATION LABEL

1. The vehicle safety certification label is attached to face of left door pillar.
2. This label indicates Gross Vehicle Weight Rating (G.V.W.R.), Gross Axle Weight Rating (G.A.W.R.) front, rear and Vehicle Identification Number (V.I.N.).

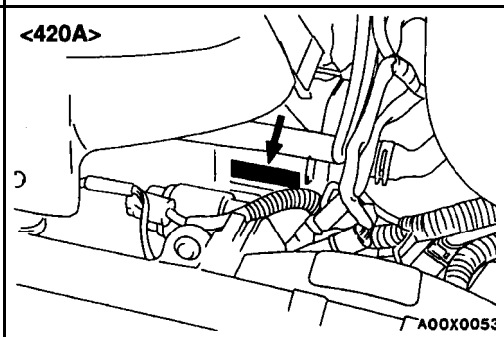

ENGINE MODEL STAMPING

1. The engine model number is stamped at the front side on the top edge of the cylinder block as shown in the following.

Engine model	Engine displacement
420A	2.0 dm ³ (122.0 cu.in.)
4G63	2.0 dm ³ (122.0 cu.in.)
4G64	2.4 dm ³ (146.5 cu.in.)

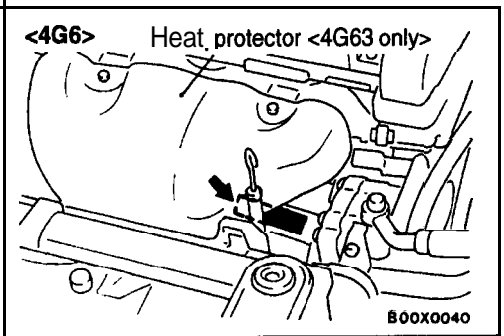

2. The 4G6 and 420A engine serial number is stamped near the engine model number, and the serial number cycles, as shown below.

Engine serial number	AA0201 to YY9999
----------------------	------------------

Theft protection label

For original parts



MITSUBISHI IHSIBUSIIM MITSUBISHI

0020014

For replacement parts



0020015

00004743

THEFT PROTECTION

In order to protect against theft, a Vehicle Identification Number (VIN) is stamped in, or attached as a label to, the following major parts of the engine and transaxle, **as well** as main outer panels:

Engine cylinder block, Transaxle housing, **Fender**, Door, Quarter panel, Hood, Liftgate, Trunk lid, Bumpers

In addition, a theft-protection label is attached to replacement parts for the body outer panel main **components**, and the same data are stamped into replacement parts for the engine and the transaxle.

Cautions regarding panel repairs:

1. When repainting original **parts**, **do so after first masking the theft-protection label**, and, after **painting**, be sure to peel off the masking tape.
2. The theft-protection label for **replacement parts is covered by masking tape**, so such part&an be **painted as is**. The masking tape should be removed **after painting is finished**.
3. The theft-protection label should not be **removed from original parts or replacement parts**.

LOCATIONS

Target area (A: for original equipment parts, B: for replacement parts)

Engine

<2.0L Engine (Non-turbo)>

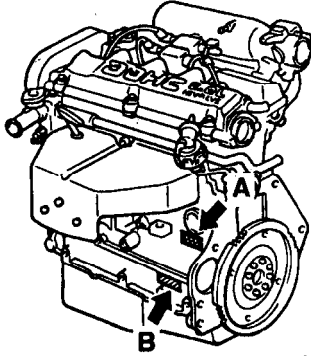

00X0095

<2.0L Engine (Turbo)>

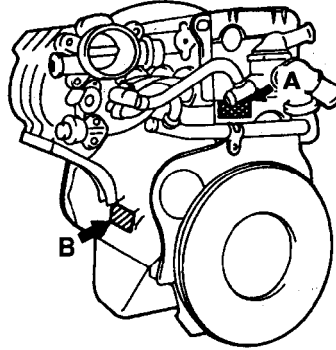

00X0050

<2.4L Engine>

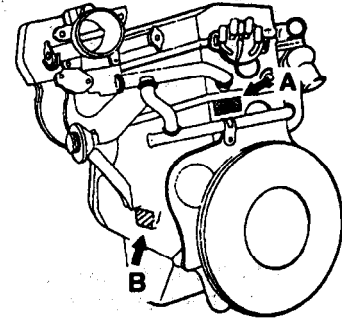

00A0231

00004111

Manual transaxle

<2.0L Engine (Non-turbo)>

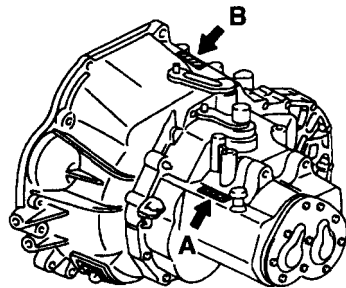

00X0092

<2.0L Engine (Turbo) and 2.4L Engine>

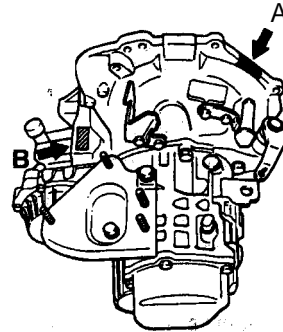

00E0048

00003676

Automatic transaxle

<2.0L Engine (Non-turbo)>

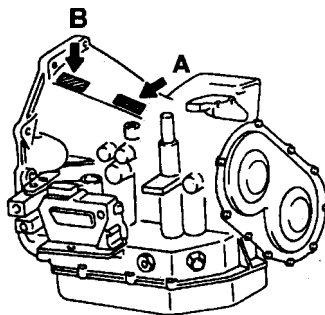

00X0093

<2.0L Engine (Turbo) and 2.4L Engine>

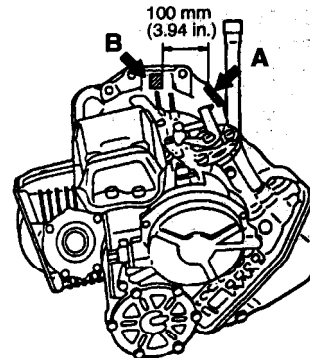

00A0223

00003679

Target area (A: for original equipment parts, B: for replacement parts)

Fender

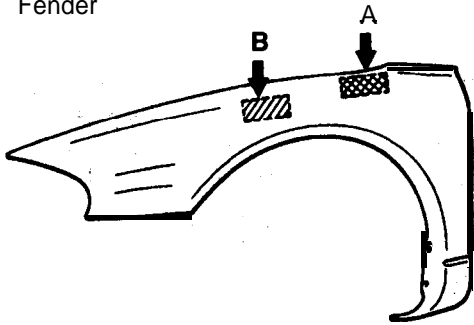

31X0321

The illustration indicates left hand side, outer. Right hand side is symmetrically opposite.

Door

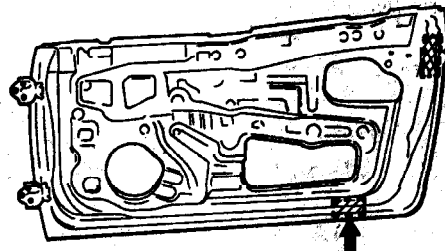

31X0354

00003680

Quarter panel

The label is attached at the inner side of the parts shown in the figure.

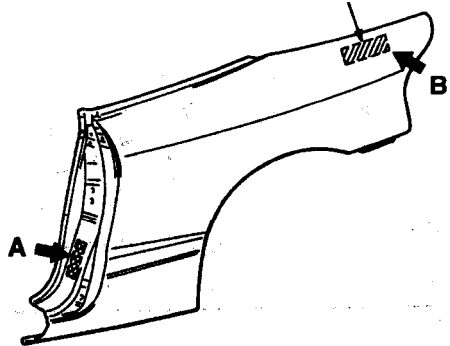

A31X0325

The illustration indicates right hand side, outer. Left hand side is symmetrically opposite.

Hood

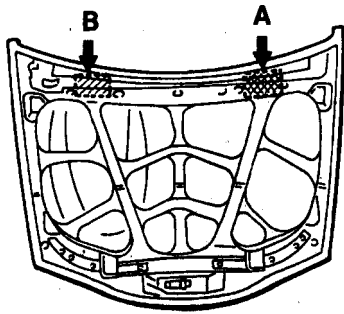

31X0356

Liftgate

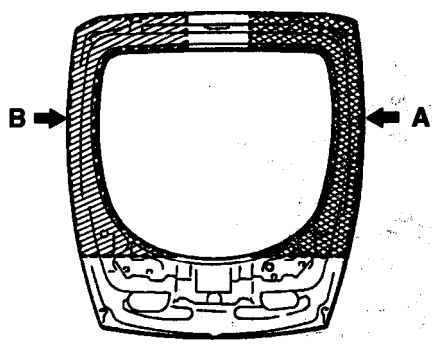

31X0473

00003661

Target area (A: for original equipment parts, B: for replacement parts)

Front bumper

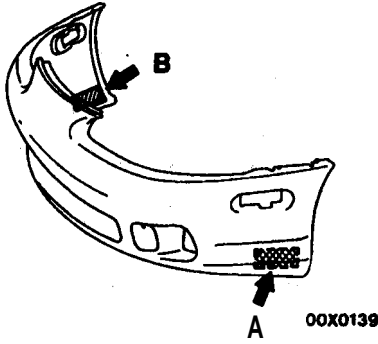

Rear bumper

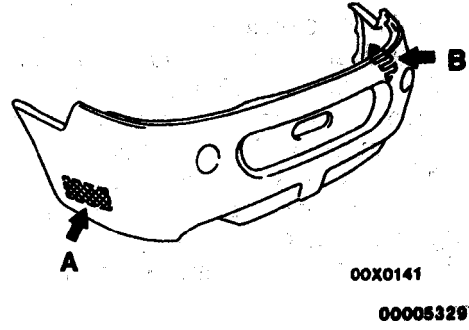

Trunk lid

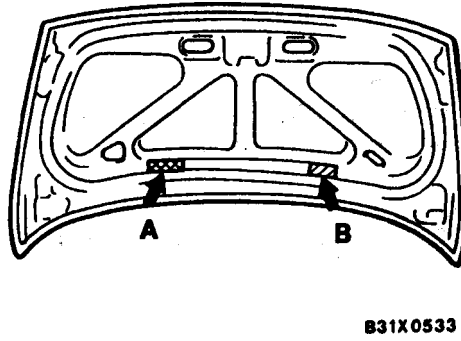

PRECAUTIONS BEFORE SERVICE

00100050083

SUPPLEMENTAL RESTRAINT SYSTEM (SRS)

1. Items to follow when servicing SRS

- (1) Be sure to read GROUP 52B – Supplemental Restraint System (SRS).
For safe operations, please follow the directions and heed all **warnings**.
- (2) Always use the designated special tools and test equipment.
- (3) Wait at least 60 seconds after disconnecting the battery cable before **doing any** further work;
The SRS system is designed to retain enough voltage to deploy the air bag even after the battery has been disconnected. Serious injury may result from unintended air bag deployment if work is done on the SRS system immediately after the battery cable is disconnected.
- (4) Never attempt to disassemble or repair the SRS components (SRS-ECU air bag module and clock spring). If faulty, replace it.
- (5) Warning labels must be heeded when servicing or handling SRS components. Warning labels are located in the following locations.
 - Sun visor
 - Glove box
 - SRS-ECU
 - Steering wheel
 - Air bag module
 - Clock spring
 - Steering gear and linkage clamp
- (6) Store components removed from the SRS in a clean and dry place.
The air bag module should be stored on a flat surface and placed so that the pad surface is facing upward.
Do not place anything on top of it.
- (7) Be sure to deploy the air bag before disposing of the air bag module or disposing of a vehicle equipped with an air bag. (Refer to GROUP 52B – Air Bag Module Disposal Procedures.)
- (8) Whenever you finish servicing the SRS, check the SRS warning light operation to make sure that the system functions properly.

2. Observe the following when carrying out operations on places where SRS components are installed, including operations not directly related to the SRS air bag.

- (1) When removing or installing parts do not allow any impact or shock to the SRS components.
- (2) SRS components should not be subjected to heat over **93°C (200°F)**, so remove the SRS components before drying or baking the vehicle after painting.
After re-installing them, check the SRS warning light operation to make sure that the system functions properly.

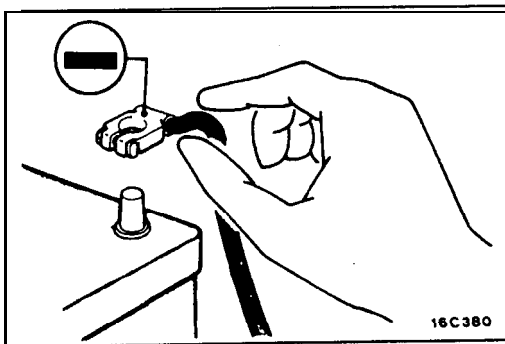

SERVICING THE ELECTRICAL SYSTEM

1. Note the following before proceeding with work on the electrical system.
Note that the following must never be done:
Unauthorized modifications of any electrical device or wiring, because such modifications might lead to a vehicle malfunction, over-capacity or short-circuit that could result in a fire in the vehicle.
2. When servicing the electrical system, disconnect the negative cable terminal from the battery.

Caution

1. Before connecting or disconnecting the negative **cable**, be sure to turn off the ignition **switch** and the lighting switch.
(if this is not done, **there is** the possibility of semi-conductor parts being damaged.)
2. After completion of the work steps [when the battery's negative (-) terminal is connected], warm up the engine and allow it to **idle** for approximately five minutes under the conditions **described** below, in order to stabilize the engine **control** conditions, and then check to be sure that idling' is satisfactory.

Engine **coolant** temperature: **80–95°C (176–203°F)**

Lights, electric fans, accessories: **OFF**

Transaxle: **Neutral** position

(A/T models: “**N**” or “**P**”)

Steering **wheel**: **neutral** (center) position

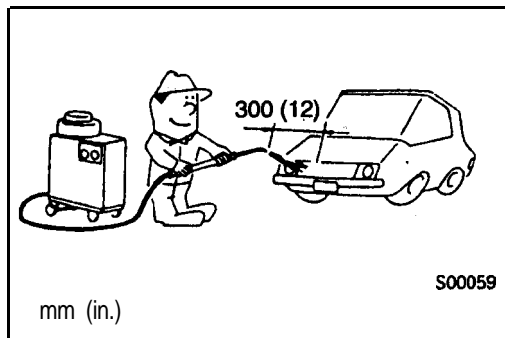
**VEHICLE WASHING**

If high-pressure car-washing equipment or steam car-washing equipment is used to wash the vehicle, be **sure** to maintain the spray nozzle at a distance of at least 300 mm (12 in.) from any plastic parts and all opening parts (doors, luggage compartment, etc.).

APPLYING ANTI-CORROSION AGENT OR OTHER UNDERCOAT AGENTS.

Be careful not to adhere oil or grease to the heated oxygen sensor. If adhered, the sensor may malfunction.

Protect the heated oxygen sensor with a cover before applying anti-corrosion agent, etc.

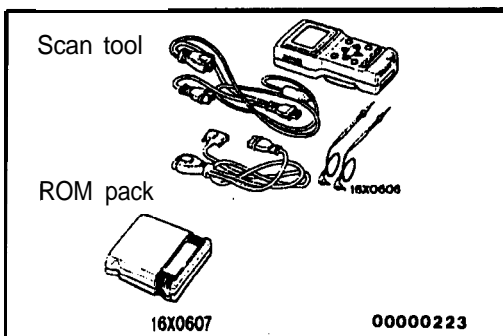
**SCAN TOOL**

To operate the scan tool, refer to the “MUT-II OPERATING INSTRUCTIONS”.

Caution

Turn the ignition switch off before connecting and disconnecting the scan tool.

TOWING AND HOISTING

00100080068

Sling type

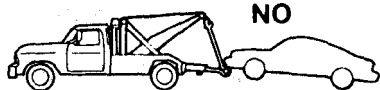

Wheel lift type



Flat bed type

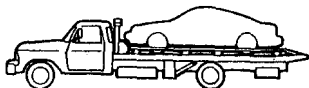

Dolly type



00X0085

Sling type



Wheel lift type



Flat bet type

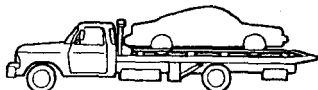

Dolly type



00X0086

<FWD>

WRECKER TOWING RECOMMENDATION**FRONT TOWING PICKUP****Caution**

This vehicle cannot be towed by a wrecker using sling type equipment to prevent the bumper from deformation. if this vehicle is towed, use **wheel lift type**, **flat bed type** or **dolly type** equipment.

The vehicle may be towed on its rear wheels for extended distances provided the parking brake is released. It is recommended that vehicles be towed using the front pickup whenever possible.

REAR TOWING PICKUP**Caution**

1. This vehicle cannot be towed by a wrecker using **sling-type** equipment to prevent the **bumper** from 'deformation'. if this vehicle is towed, use **wheel lift type**, **flat bed type** or **doily type** equipment.
2. Do not use steering **column lock** to secure front **wheel position** for towing.
3. Make sure the transaxle is in Neutral if **vehicle will be with drive wheels** on the ground.

Automatic transaxle vehicle may be towed on the front wheels at speeds not to exceed 50 km/h (30 mph) for distances not to exceed 30 km (18 miles).

C a u t i o n

if these limits cannot be met, the front **wheels** must be placed on a tow doily or a flat bet type must be used.

TOWING WHEN KEYS ARE NOT AVAILABLE

When a locked vehicle must be towed and **keys are not available**, the vehicle may be lifted and towed from the front; provided the parking brake is released. If not released, the rear wheels should be placed on a tow dolly.

SAFETY PRECAUTIONS

The following precautions should be **taken when** towing the vehicle.

1. **DO NOT LIFT OR TOW THE VEHICLE BY ATTACHING TO OR WRAPPING AROUND THE BUMPER.**
2. Any loose or protruding **parts of damaged** vehicle such as hoods, doors, fenders, **trim**, etc., should be secured or removed prior to moving **the** vehicle.
3. Operator should refrain **from** going under a vehicle while it is lifted by the towing **equipment**, unless the vehicle is adequately supported by safety stands.
4. Never allow passengers to ride in a towed vehicle.
5. State and local rules and regulations must be followed when towing a vehicle.

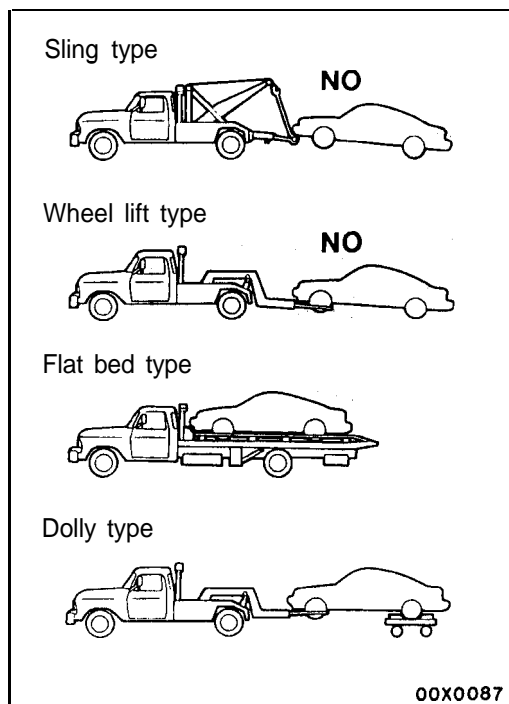
**<AWD>****Caution**

1. If only the front wheels or only the rear wheels are lifted for towing, the bumper will be damaged. In addition, lifting of the rear wheels causes the oil to flow forward, and may result in heat damage to the rear bushing of the transfer, and **so** should never be done.
2. Do not tow the vehicle with "only its front wheels or only the rear wheels on a **rolling** dolly, or the viscous coupling will be damaged. In a **worst** case, the vehicle may jump forward suddenly.
3. If this vehicle is towed, use **flat bed type or dolly type** equipment.

LIFTING, JACKING SUPPORT LOCATION
FLOOR JACK

<FWD>

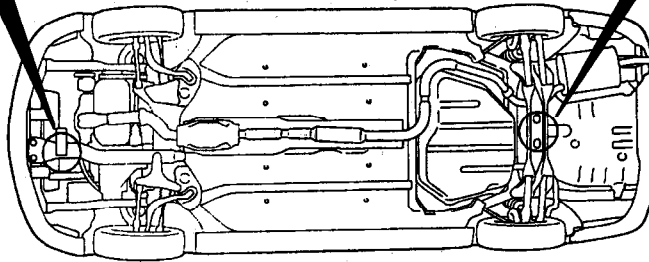
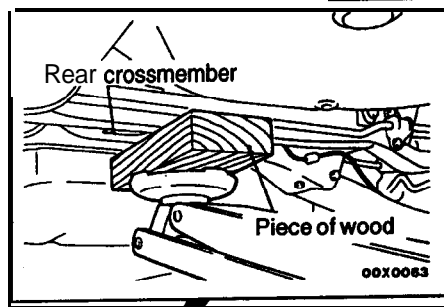
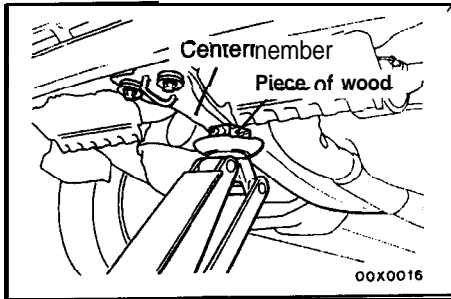

<AWD>

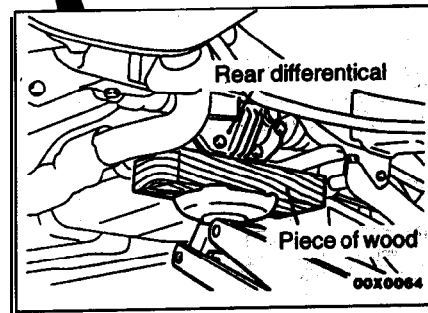
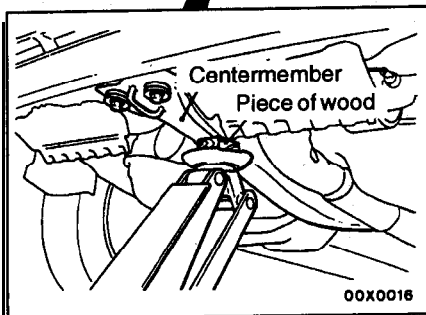
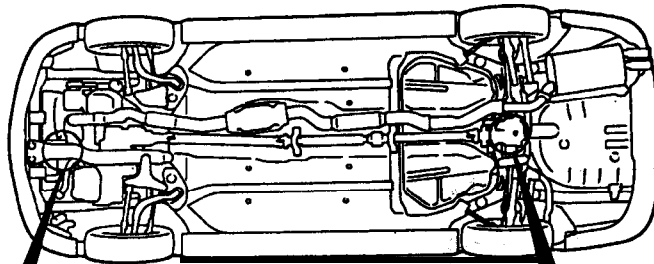

00003684

Caution
Never support any point other than the specified one, or it will be deformed.

RIGID RACK

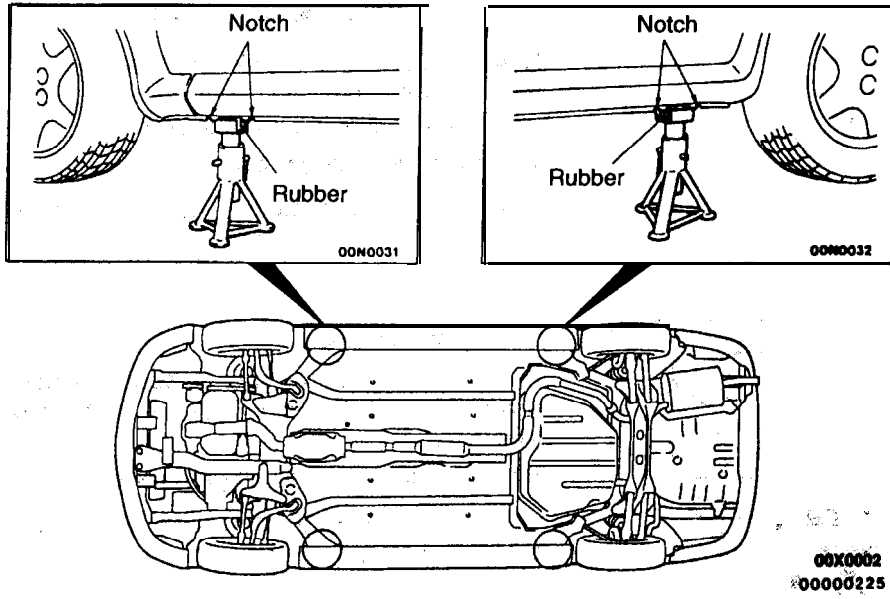

Caution

For lifting, put rubber or similar between the side sill and rigid rack, or the side sill area will be damaged.

POST TYPE

Special care should be taken when raising the vehicle on a frame contact type hoist. The hoist must be equipped with the proper adapters in order to support the vehicle at the proper locations.

Caution

When service procedures require removing rear suspension, fuel tank and spare tire, place additional weight on rear end of vehicle or anchor vehicle to hoist to prevent tipping of center of gravity changes.

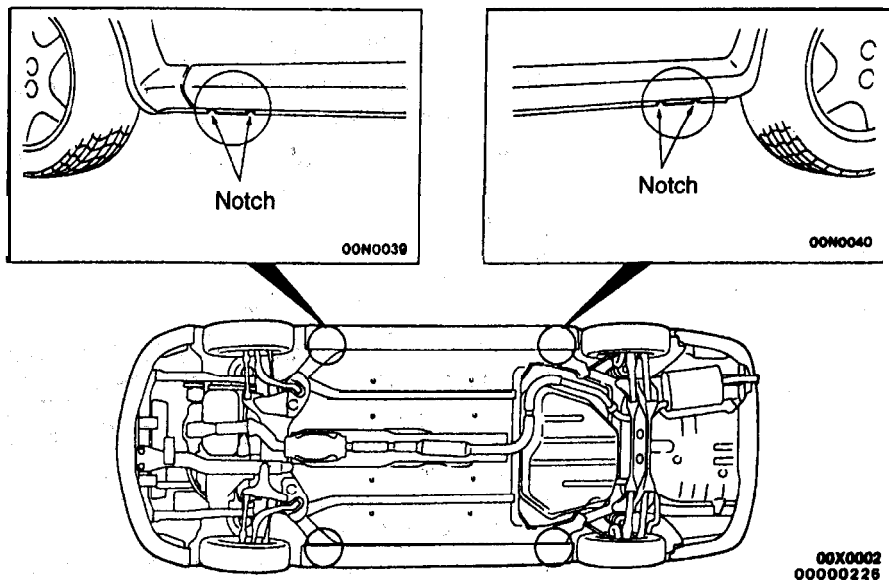

SPECIAL HANDLING INSTRUCTIONS FOR AWD MODELS

00100740010

Speedometer tests, brake tests and wheel balance measurement for full-time AWD vehicles should be carried out according to the following procedures.

SPEEDOMETER TEST

Refer to GROUP 54 – Combination Meter.

BRAKE TEST

In order to stabilize the viscous coupling's dragging force, the brake test should always be conducted after the speedometer test.

FRONT WHEEL MEASUREMENTS

1. Place the front wheels on the brake tester.
2. Perform the brake test.

Caution

The rear wheels should remain on the ground.

3. If the brake dragging force exceeds the specified value, jack up the vehicle and manually rotate each wheel -to check the rotation condition of each wheel.

NOTE

If the brake dragging force exceeds the specified value, the cause may be the effect of the viscous coupling's dragging force, so jack up the front wheels and check the rotation condition of the wheels in this state for no effect by the viscous coupling's dragging force.

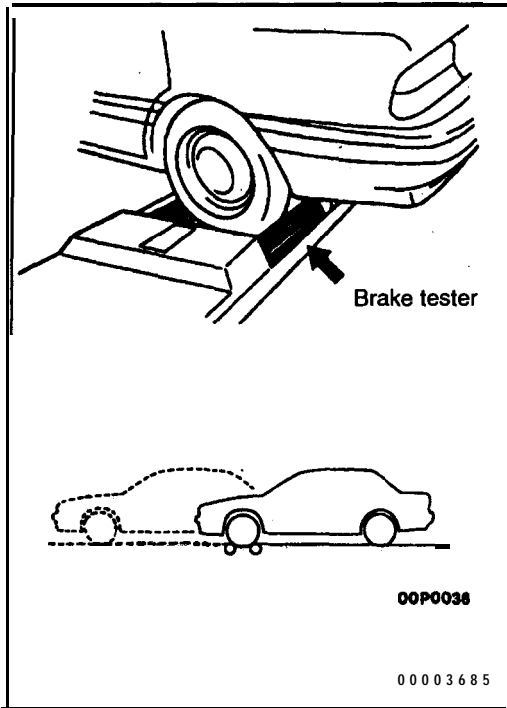

REAR WHEEL MEASUREMENTS

After placing the rear wheels on the brake tester, follow the same procedures as for the front wheel measurements.

Brake force of AWD models with VCU

If both front wheels are locked and rear wheel measurement is difficult, the measurement in this condition can be considered to comprise the total.

Items	Brake force	
Total for left and right rear wheels	At 90 kg (198 lbs.) pedal depression force	- 20 % or more of rear axle weight
Difference for left and right front wheels/difference for left and right rear wheels	8% or less of rear axle weight	8% or less of rear axle weight
Total for front and rear wheels	At 90 kg (198 lbs.) pedal depression force	- 50% or more of the vehicle's weight

or...

Braking-stop distance	At primary velocity of 50 km/h (31 mph): Within 15.0 m (49.2 ft.)
-----------------------	---

TSB Revision

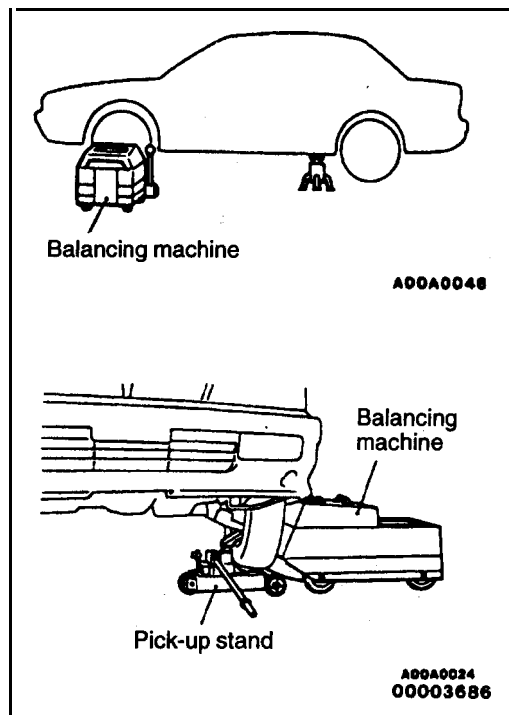

WHEEL BALANCE

FRONT WHEEL MEASUREMENTS

1. Jack up the rear wheels, and place an axle **stand** at the designated part of the side sill.
2. Jack up the front wheels and set, a pick-up stand and balancing machine in place.

Caution

1. **Set so that the front and rear of the vehicle are at the same height.**
 2. **Release the parking brake.**
 3. **Rotate each wheel manually and check to be sure that there is no dragging.**
3. Use the engine to drive the tyres, and then make the measurement.

Caution

1. **If an error is indicated in the state of engine drive, motor drive can be used concurrently.**
2. **Do not operate the clutch suddenly, or increase or reduce speed suddenly during the work.**

REAR WHEEL MEASUREMENTS

1. Jack up the front wheels, and 'place an, 'axle stand at the designated part of the side sill.'
2. Jack up the rear wheels, and then, **after** setting a pick-up stand and balancing machine in place, follow the same procedure **as** for front wheel measurements.

GENERAL DATA AND SPECIFICATIONS

00199999191

ECLIPSE

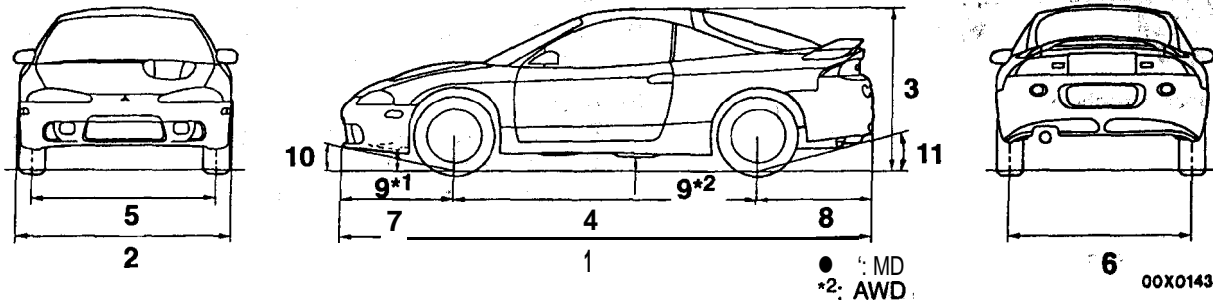

GENERAL SPECIFICATIONS

<FWD>

Items		D31AMNSML4M D31AMNSML9M	D31AMRSML4M D31AMRSML9M	D31AMNJML4M D31AMNJML9M	D31AMRJML4M D31AMRJML9M
Vehicle dimensions	Overall length mm (in.)	1 4,380 (172.4)	4,380 (172.4)	4,380 (172.4)	4,380 (172.4)
	Overall width mm	2 1,735 (68.3)	1,735 (68.3)	1,735 (68.3)	1,735 (68.3)
	Overall height (unladen) mm (in.)	3 1,295 (51.0)	1,295 (51.0)	1,295 (51.0)	1,295 (51.0)
	Wheelbase mm (in.)	4 2,510 (98.8)	2,510 (98.8)	2,510 (98.8)	2,510 (98.8)
	Tread – Front mm (in.)	5 1,515 (59.6)	1,515 (59.6)	1,515 (59.6)	1,515 (59.6)
	Tread – Rear mm (in.)	6 1,510 (59.4)	1,510 (59.4)	1,510 (59.4)	1,510 (59.4)
	Overhang – Front mm (in.)	7 935 (36.8)	935 (36.8)	935 (36.8)	935 (36.8)
	Overhang – Rear mm (in.)	8 935 (36.8)	935 (36.8)	935 (36.8)	935 (36.8)
	Minimum running ground clearance mm (in.)	9 145 (5.7)	145 (5.7)	145 (5.7)	145 (5.7)
	Angle of approach degrees	10 11.8	11.8	11.8	11.8
Angle of departure degrees	11 15.8	15.8	15.8	15.8	
Vehicle weight (kg (lbs.))	Curb weight	1,236 (2,725)	1,266 (2,791)	1,245 (2,745)	1,275 (2,811)
	Gross vehicle weight rating	1,660 (3,660)	1,660 (3,660)	1,690 (3,726)	1,690 (3,726)
	Gross axle weight rating – Front	1,010 (2,227)	1,010 (2,227)	1,010 (2,227)	1,010 (2,227)
	Gross axle weight rating – Rear	800 (1,764)	800 (1,764)	800 (1,764)	800 (1,764)
Seating capacity		4	4	4	4
Engine	Model No.	420A (DOHC)	420A (DOHC)	420A (DOHC)	420A (DOHC)
	Piston displacement cm ³ (cu.in.)	1,996 (121.8)	1,996 (121.8)	1,996 (121.8)	1,996 (121.8)
Trans-axle	Model No.	F5MC1	F4AC1	F5MC1	F4AC1
	Type	5-speed manual	4-speed automatic	5-speed manual	4-speed automatic
Fuel system	Fuel supply system	Electronically controlled multi-port fuel injection	Electronically controlled multi-port fuel injection	Electronically controlled multi-port fuel injection	Electronically controlled multi-port fuel injection