

HOW TO USE THIS MANUAL

This manual is intended as a handy, easy-to-read reference book for the mechanic. Comprehensive explanations of all installation, removal, disassembly, assembly, repair and check procedures are laid out with the individual steps in sequential order.

- ① The manual is divided into chapters. An abbreviation and symbol in the upper right corner of each page indicate the current chapter. Refer to "SYMBOLS".
- ② Each chapter is divided into sections. The current section title is shown at the top of each page, except in Chapter 3 ("PERIODIC CHECKS AND ADJUSTMENTS"), where the sub-section title(s) appears.
- ③ Sub-section titles appear in smaller print than the section title.
- ④ To help identify parts and clarify procedure steps, there are exploded diagrams at the start of each removal and disassembly section.
- ⑤ Numbers are given in the order of the jobs in the exploded diagram. A circled number indicates a disassembly step.
- ⑥ Symbols indicate parts to be lubricated or replaced. Refer to "SYMBOLS".
- ⑦ A job instruction chart accompanies the exploded diagram, providing the order of jobs, names of parts, notes in jobs, etc.
- ⑧ Jobs requiring more information (such as special tools and technical data) are described sequentially.

②
①

CLUTCH
ENG

EXAMINER:
CLUTCH
CLUTCH COVER

Order	Job/Part	Q'ty	Remarks
Removing the clutch cover			
	Bottom cowling		Removing the parts in the order listed.
	Right side cowling		Refer to "COWLINGS" in chapter 3.
	Engine oil		Drain.
			Refer to "CHANGING THE ENGINE OIL" in chapter 3.
	Coolant		Drain.
			Refer to "CHANGING THE COOLANT" in chapter 3.
1	Coolant hose	1	Disconnect.
2	Clutch cable	1	Disconnect.
3	Clutch cover	1	
4	Clutch cover gasket	1	
5	Dowel pin	2	
For installation, reverse the removal procedure.			

CLUTCH
ENG

EXAMINER:
REMOVING THE CLUTCH

1. Remove:
• clutch cover ①
• gasket

NOTE:
Loosen each bolt 1/4 of a turn at a time, in stages and in a crisscross pattern. After all of the bolts are fully loosened, remove them.

2. Remove:
• compression spring bolts ①
• compression springs
• pressure plate ②
• pull rod ③
• friction plates
• clutch plates

3. Straighten the lock washer tab.

4. Loosen:
• clutch boss nut ①





















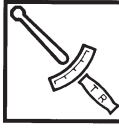

NOTE:
While holding the clutch boss ② with the universal clutch holder, loosen the clutch boss nut.

Universal clutch holder
90890-04086, YM-91042

5. Remove:
• clutch boss nut ①
• lock washer ②
• clutch boss ③
• thrust plate ④

EXAMINER:
CHECKING THE FRICTION PLATES
The following procedure applies to all of the friction plates.

1. Check:
• friction plate
Damage/wear → Replace the friction plates as a set.

① GEN INFO 	② SPEC 	
③ CHK ADJ 	④ CHAS 	
⑤ ENG 	⑥ COOL 	
⑦ FI 	⑧ ELEC 	
⑨ TRBL SHTG ?	⑩ 	
⑪ 	⑫ 	
⑬ 	⑭ 	
⑮ 	⑯ 	⑰ 
⑱ 	⑲ 	⑳ 
㉑ 	㉒ 	㉓ 
㉔ 	㉕ New	

SYMBOLS

The following symbols are not relevant to every vehicle.

Symbols ① to ⑨ indicate the subject of each chapter.

- ① General information
- ② Specifications
- ③ Periodic checks and adjustments
- ④ Chassis
- ⑤ Engine
- ⑥ Cooling system
- ⑦ Fuel injection system
- ⑧ Electrical system
- ⑨ Troubleshooting

Symbols ⑩ to ⑰ indicate the following.

- ⑩ Serviceable with engine mounted
- ⑪ Filling fluid
- ⑫ Lubricant
- ⑬ Special tool
- ⑭ Tightening torque
- ⑮ Wear limit, clearance
- ⑯ Engine speed
- ⑰ Electrical data









Symbols ⑱ to ㉓ in the exploded diagrams indicate the types of lubricants and lubrication points.

- ⑱ Engine oil
- ⑲ Gear oil
- ⑳ Molybdenum-disulfide oil
- ㉑ Wheel-bearing grease
- ㉒ Lithium-soap-based grease
- ㉓ Molybdenum-disulfide grease

Symbols ㉔ to ㉕ in the exploded diagrams indicate the following.

- ㉔ Apply locking agent (LOCTITE®)
- ㉕ Replace the part

TABLE OF CONTENTS

GENERAL INFORMATION	 GEN INFO 1
SPECIFICATIONS	 SPEC 2
PERIODIC CHECKS AND ADJUSTMENTS	 CHK ADJ 3
CHASSIS	 CHAS 4
ENGINE	 ENG 5
COOLING SYSTEM	 COOL 6
FUEL INJECTION SYSTEM	 FI 7
ELECTRICAL SYSTEM	 ELEC 8
TROUBLESHOOTING	 TRBL SHTG 9

CHAPTER 1 GENERAL INFORMATION

MOTORCYCLE IDENTIFICATION	1-1
VEHICLE IDENTIFICATION NUMBER	1-1
MODEL LABEL	1-1
FEATURES	1-2
OUTLINE OF FI SYSTEM	1-2
FI SYSTEM	1-3
INSTRUMENT FUNCTION	1-4
IMPORTANT INFORMATION	1-7
PREPARATION FOR REMOVAL AND DISASSEMBLY	1-7
REPLACEMENT PARTS	1-7
GASKETS, OIL SEALS AND O-RINGS	1-7
LOCK WASHERS/PLATES AND COTTER PINS	1-8
BEARINGS AND OIL SEALS	1-8
CIRCLIPS	1-8
CHECKING THE CONNECTIONS	1-9
SPECIAL TOOLS	1-10

CHAPTER 2 SPECIFICATIONS

GENERAL SPECIFICATIONS	2-1
ENGINE SPECIFICATIONS	2-2
CHASSIS SPECIFICATIONS	2-11
ELECTRICAL SPECIFICATIONS	2-15
CONVERSION TABLE	2-18
GENERAL TIGHTENING TORQUE SPECIFICATIONS	2-18
TIGHTENING TORQUES	2-19
ENGINE TIGHTENING TORQUES	2-19
CHASSIS TIGHTENING TORQUES	2-22
LUBRICATION POINTS AND LUBRICANT TYPES	2-24
ENGINE	2-24
CHASSIS	2-25
COOLING SYSTEM DIAGRAMS	2-26

ENGINE OIL LUBRICATION CHART	2-30
LUBRICATION DIAGRAMS	2-31
CABLE ROUTING	2-37

CHAPTER 3 PERIODIC CHECKS AND ADJUSTMENTS

INTRODUCTION	3-1
PERIODIC MAINTENANCE CHART FOR THE EMISSION CONTROL SYSTEM	3-1
GENERAL MAINTENANCE AND LUBRICATION CHART	3-1
SEATS	3-3
FUEL TANK	3-4
REMOVING THE FUEL TANK	3-5
REMOVING THE FUEL PUMP	3-5
INSTALLING THE FUEL PUMP	3-6
INSTALLING THE FUEL TANK	3-6
COWLINGS	3-7
REMOVAL	3-8
INSTALLATION	3-8
AIR FILTER CASE	3-9
ENGINE	3-10
ADJUSTING THE VALVE CLEARANCE	3-10
SYNCHRONIZING THE THROTTLE BODIES	3-16
ADJUSTING THE ENGINE IDLING SPEED	3-18
ADJUSTING THE THROTTLE CABLE FREE PLAY	3-19
CHECKING THE SPARK PLUGS	3-21
MEASURING THE COMPRESSION PRESSURE	3-22
CHECKING THE ENGINE OIL LEVEL	3-24
CHANGING THE ENGINE OIL	3-25
MEASURING THE ENGINE OIL PRESSURE	3-27
ADJUSTING THE CLUTCH CABLE FREE PLAY	3-29
CLEANING THE AIR FILTER ELEMENT	3-30
CLEANING THE AIR INTAKE SYSTEM SURGE TANKS	3-31
CHECKING THE THROTTLE BODY JOINTS	3-31
CHECKING THE FUEL AND BREATHER HOSES	3-32
CHECKING THE CRANKCASE BREATHER HOSE	3-32
CHECKING THE EXHAUST SYSTEM	3-33
CHECKING THE COOLANT LEVEL	3-33
CHECKING THE COOLING SYSTEM	3-34
CHANGING THE COOLANT	3-35

CHASSIS	3-39
ADJUSTING THE FRONT BRAKE	3-39
ADJUSTING THE REAR BRAKE	3-40
CHECKING THE BRAKE FLUID LEVEL	3-41
ADJUSTING THE REAR BRAKE LIGHT SWITCH	3-42
CHECKING THE FRONT AND REAR BRAKE PADS	3-43
CHECKING THE FRONT AND REAR BRAKE HOSES	3-43
BLEEDING THE HYDRAULIC BRAKE SYSTEM	3-44
ADJUSTING THE SHIFT PEDAL	3-45
ADJUSTING THE DRIVE CHAIN SLACK	3-46
LUBRICATING THE DRIVE CHAIN	3-47
CHECKING AND ADJUSTING THE STEERING HEAD	3-48
CHECKING THE FRONT FORK	3-50
ADJUSTING THE FRONT FORK LEGS	3-51
ADJUSTING THE REAR SHOCK ABSORBER ASSEMBLY	3-53
CHECKING THE TIRES	3-55
CHECKING THE WHEELS	3-57
CHECKING AND LUBRICATING THE CABLES	3-58
LUBRICATING THE LEVERS AND PEDALS	3-58
LUBRICATING THE SIDESTAND	3-58
LUBRICATING THE REAR SUSPENSION	3-58
ELECTRICAL SYSTEM	3-59
CHECKING AND CHARGING THE BATTERY	3-59
CHECKING THE FUSES	3-64
REPLACING THE HEADLIGHT BULBS	3-66
ADJUSTING THE HEADLIGHT BEAMS	3-67

CHAPTER 4 CHASSIS

FRONT WHEEL AND BRAKE DISCS	4-1
REMOVING THE FRONT WHEEL	4-3
CHECKING THE FRONT WHEEL	4-3
CHECKING THE BRAKE DISCS	4-5
INSTALLING THE FRONT WHEEL	4-6
ADJUSTING THE FRONT WHEEL STATIC BALANCE	4-7
REAR WHEEL AND BRAKE DISC	4-9
REAR WHEEL	4-9
REAR BRAKE DISC AND REAR WHEEL SPROCKET	4-10
REMOVING THE REAR WHEEL	4-12
CHECKING THE REAR WHEEL	4-13
CHECKING THE REAR WHEEL DRIVE HUB	4-13
CHECKING AND REPLACING THE REAR WHEEL SPROCKET	4-13
INSTALLING THE REAR WHEEL	4-14
ADJUSTING THE REAR WHEEL STATIC BALANCE	4-15

FRONT AND REAR BRAKES	4-16
FRONT BRAKE PADS	4-16
REAR BRAKE PADS	4-17
REPLACING THE FRONT BRAKE PADS	4-18
REPLACING THE REAR BRAKE PADS	4-21
FRONT BRAKE MASTER CYLINDER	4-23
REAR BRAKE MASTER CYLINDER	4-26
DISASSEMBLING THE FRONT BRAKE MASTER CYLINDER ..	4-28
DISASSEMBLING THE REAR BRAKE MASTER CYLINDER	4-28
CHECKING THE FRONT AND REAR BRAKE MASTER CYLINDERS	4-29
ASSEMBLING AND INSTALLING THE FRONT BRAKE MASTER CYLINDER	4-30
ASSEMBLING THE REAR BRAKE MASTER CYLINDER	4-32
FRONT BRAKE CALIPERS	4-34
REAR BRAKE CALIPER	4-36
DISASSEMBLING THE FRONT BRAKE CALIPERS	4-38
DISASSEMBLING THE REAR BRAKE CALIPER	4-39
CHECKING THE FRONT AND REAR BRAKE CALIPERS	4-40
ASSEMBLING AND INSTALLING THE FRONT BRAKE CALIPERS	4-41
ASSEMBLING AND INSTALLING THE REAR BRAKE CALIPER .	4-43
FRONT FORK	4-45
FRONT FORK LEGS	4-45
REMOVING THE FRONT FORK LEGS	4-48
DISASSEMBLING THE FRONT FORK LEGS	4-49
CHECKING THE FRONT FORK LEGS	4-50
ASSEMBLING THE FRONT FORK LEGS	4-51
INSTALLING THE FRONT FORK LEGS	4-56
HANDLEBARS	4-58
REMOVING THE HANDLEBARS	4-59
CHECKING THE HANDLEBARS	4-59
INSTALLING THE HANDLEBARS	4-60
STEERING HEAD	4-63
UNDER BRACKET	4-63
REMOVING THE UNDER BRACKET	4-65
CHECKING THE STEERING HEAD	4-65
INSTALLING THE STEERING HEAD	4-66

REAR SHOCK ABSORBER ASSEMBLY	4-68
HANDLING THE REAR SHOCK ABSORBER AND GAS CYLINDER	4-70
DISPOSING OF A REAR SHOCK ABSORBER AND GAS CYLINDER	4-70
REMOVING THE REAR SHOCK ABSORBER ASSEMBLY	4-71
CHECKING THE REAR SHOCK ABSORBER ASSEMBLY AND GAS CYLINDER	4-71
CHECKING THE CONNECTING ROD AND RELAY ARMS	4-72
INSTALLING THE REAR SHOCK ABSORBER ASSEMBLY	4-72
SWINGARM AND DRIVE CHAIN	4-73
REMOVING THE SWINGARM	4-75
REMOVING THE DRIVE CHAIN	4-76
CHECKING THE SWINGARM	4-76
CHECKING THE DRIVE CHAIN	4-77
INSTALLING THE SWINGARM	4-79

CHAPTER 5 OVERHAULING THE ENGINE

ENGINE	5-1
DRIVE SPROCKET	5-1
EXHAUST PIPE	5-2
LEADS AND HOSES	5-3
ENGINE	5-5
INSTALLING THE ENGINE	5-6
CAMSHAFTS	5-8
CYLINDER HEAD COVER	5-8
CAMSHAFTS	5-9
REMOVING THE CAMSHAFTS	5-10
CHECKING THE CAMSHAFTS	5-11
CHECKING THE TIMING CHAIN, CAMSHAFT SPROCKETS, AND TIMING CHAIN GUIDES	5-13
CHECKING THE TIMING CHAIN TENSIONER	5-13
INSTALLING THE CAMSHAFTS	5-14
CYLINDER HEAD	5-18
REMOVING THE CYLINDER HEAD	5-19
CHECKING THE CYLINDER HEAD	5-19
INSTALLING THE CYLINDER HEAD	5-20

VALVES AND VALVE SPRINGS	5-21
REMOVING THE VALVES	5-23
CHECKING THE VALVES AND VALVE GUIDES	5-24
CHECKING THE VALVE SEATS	5-26
CHECKING THE VALVE SPRINGS	5-28
CHECKING THE VALVE LIFTERS	5-29
INSTALLING THE VALVES	5-29
STARTER CLUTCH AND GENERATOR	5-31
STATOR COIL ASSEMBLY	5-31
REMOVING THE GENERATOR	5-33
REMOVING THE STARTER CLUTCH	5-34
CHECKING THE STARTER CLUTCH	5-35
INSTALLING THE STARTER CLUTCH	5-35
INSTALLING THE GENERATOR	5-36
SHIFT SHAFT	5-38
SHIFT SHAFT AND STOPPER LEVER	5-38
CHECKING THE SHIFT SHAFT	5-40
CHECKING THE STOPPER LEVER	5-40
INSTALLING THE SHIFT SHAFT	5-40
CRANKSHAFT POSITION SENSOR AND PICKUP ROTOR	5-41
REMOVING THE PICKUP ROTOR	5-43
INSTALLING THE PICKUP ROTOR	5-43
CLUTCH	5-45
CLUTCH COVER	5-45
CLUTCH	5-47
REMOVING THE CLUTCH	5-48
CHECKING THE FRICTION PLATES	5-48
CHECKING THE CLUTCH PLATES	5-49
CHECKING THE CLUTCH SPRINGS	5-49
CHECKING THE CLUTCH HOUSING	5-50
CHECKING THE CLUTCH BOSS	5-50
CHECKING THE PRESSURE PLATE	5-50
CHECKING THE PULL LEVER SHAFT AND PULL ROD	5-51
INSTALLING THE CLUTCH	5-51

OIL PAN AND OIL PUMP	5-54
REMOVING THE OIL PAN	5-57
CHECKING THE OIL PUMP	5-57
CHECKING THE RELIEF VALVE	5-58
CHECKING THE OIL DELIVERY PIPE AND OIL PIPE	5-58
CHECKING THE OIL STRAINER	5-58
CHECKING THE OIL NOZZLES	5-58
ASSEMBLING THE OIL PUMP	5-59
INSTALLING THE OIL PUMP	5-59
INSTALLING THE OIL STRAINER	5-60
INSTALLING THE OIL PAN	5-60
CRANKCASE	5-61
DISASSEMBLING THE CRANKCASE	5-63
CHECKING THE CRANKCASE	5-64
CHECKING THE BEARINGS AND OIL SEALS	5-64
CHECKING THE TIMING CHAIN	5-64
ASSEMBLING THE CRANKCASE	5-64
CONNECTING RODS AND PISTONS	5-66
REMOVING THE CONNECTING RODS AND PISTONS	5-67
REMOVING THE CRANKSHAFT ASSEMBLY	5-68
CHECKING THE CYLINDER AND PISTON	5-68
CHECKING THE PISTON RINGS	5-69
CHECKING THE PISTON PINS	5-70
CHECKING THE BIG END BEARINGS	5-71
INSTALLING THE CONNECTING ROD AND PISTON	5-74
CRANKSHAFT	5-78
CHECKING THE CRANKSHAFT	5-79
CHECKING THE CRANKSHAFT JOURNAL BEARINGS	5-79
INSTALLING THE CRANKSHAFT	5-82
TRANSMISSION	5-83
TRANSMISSION, SHIFT DRUM ASSEMBLY AND SHIFT FORKS	5-83
REMOVING THE TRANSMISSION	5-89
CHECKING THE SHIFT FORKS	5-89
CHECKING THE SHIFT DRUM ASSEMBLY	5-90
CHECKING THE TRANSMISSION	5-90
INSTALLING THE TRANSMISSION	5-91

CHAPTER 6 COOLING SYSTEM

RADIATOR	6-1
CHECKING THE RADIATOR	6-3
INSTALLING THE RADIATOR	6-4
OIL COOLER	6-5
CHECKING THE OIL COOLER	6-6
INSTALLING THE OIL COOLER	6-6
THERMOSTAT	6-7
CHECKING THE THERMOSTAT	6-8
INSTALLING THE THERMOSTAT	6-8
WATER PUMP	6-10
DISASSEMBLING THE WATER PUMP	6-12
CHECKING THE WATER PUMP	6-13
ASSEMBLING THE WATER PUMP	6-13
INSTALLING THE WATER PUMP	6-15

CHAPTER 7 FUEL INJECTION SYSTEM

FUEL INJECTION SYSTEM	7-1
WIRING DIAGRAM	7-2
ECU'S SELF-DIAGNOSTIC FUNCTION	7-3
ALTERNATE INSTRUCTIONS OPERATION CONTROL (FAIL-SAFE ACTION)	7-4
FAIL-SAFE ACTIONS TABLE	7-4
TROUBLESHOOTING CHART	7-5
DIAGNOSTIC MODE	7-6
TROUBLESHOOTING DETAILS	7-12
THROTTLE BODIES	7-27
CHECKING THE INJECTOR	7-31
CHECKING THE THROTTLE BODY	7-31
CHECKING THE PRESSURE REGULATOR	7-32
CHECKING THE FUEL PUMP AND PRESSURE REGULATOR OPERATION	7-32
CHECKING AND ADJUSTING THE THROTTLE POSITION SENSOR	7-33
AIR INDUCTION SYSTEM	7-35
AIR INJECTION	7-35
AIR CUT-OFF VALVE	7-35
AIR INDUCTION SYSTEM DIAGRAMS	7-36
CHECKING THE AIR INDUCTION SYSTEM	7-37

CHAPTER 8 ELECTRICAL

ELECTRICAL COMPONENTS	8-1
CHECKING SWITCH CONTINUITY	8-3
CHECKING THE SWITCHES	8-4
CHECKING THE BULBS AND BULB SOCKETS	8-5
TYPES OF BULBS	8-5
CHECKING THE CONDITION OF THE BULBS	8-6
CHECKING THE CONDITION OF THE BULB SOCKETS	8-7
CHECKING THE LEDs	8-7
IGNITION SYSTEM	8-8
CIRCUIT DIAGRAM	8-8
TROUBLESHOOTING	8-9
ELECTRIC STARTING SYSTEM	8-14
CIRCUIT DIAGRAM	8-14
STARTING CIRCUIT CUT-OFF SYSTEM OPERATION	8-15
TROUBLESHOOTING	8-16
STARTER MOTOR	8-19
CHECKING THE STARTER MOTOR	8-21
ASSEMBLING THE STARTER MOTOR	8-22
CHARGING SYSTEM	8-23
CIRCUIT DIAGRAM	8-23
TROUBLESHOOTING	8-24
LIGHTING SYSTEM	8-26
CIRCUIT DIAGRAM	8-26
TROUBLESHOOTING	8-28
CHECKING THE LIGHTING SYSTEM	8-30
SIGNALING SYSTEM	8-33
CIRCUIT DIAGRAM	8-33
TROUBLESHOOTING	8-35
CHECKING THE SIGNALING SYSTEM	8-35
COOLING SYSTEM	8-42
CIRCUIT DIAGRAM	8-42
TROUBLESHOOTING	8-43

FUEL PUMP SYSTEM	8-46
CIRCUIT DIAGRAM	8-46
FUEL PUMP SYSTEM	8-47
TROUBLESHOOTING	8-48
CHECKING THE FUEL PUMP	8-50
SELF-DIAGNOSIS	8-51
TROUBLESHOOTING	8-52

CHAPTER 9 TROUBLESHOOTING

STARTING FAILURES	9-1
ENGINE	9-1
FUEL SYSTEM	9-1
ELECTRICAL SYSTEMS	9-1
INCORRECT ENGINE IDLING SPEED	9-2
ENGINE	9-2
FUEL SYSTEM	9-2
ELECTRICAL SYSTEMS	9-2
POOR MEDIUM-AND-HIGH-SPEED PERFORMANCE	9-2
ENGINE	9-2
FUEL SYSTEM	9-2
FAULTY GEAR SHIFTING	9-3
SHIFTING IS DIFFICULT	9-3
SHIFT PEDAL DOES NOT MOVE	9-3
JUMPS OUT OF GEAR	9-3
FAULTY CLUTCH	9-3
CLUTCH SLIPS	9-3
CLUTCH DRAGS	9-3
OVERHEATING	9-4
ENGINE	9-4
COOLING SYSTEM	9-4
FUEL SYSTEM	9-4
CHASSIS	9-4
ELECTRICAL SYSTEMS	9-4
OVERCOOLING	9-4
COOLING SYSTEM	9-4
POOR BRAKING PERFORMANCE	9-4
FAULTY FRONT FORK LEGS	9-5
LEAKING OIL	9-5
MALFUNCTION	9-5

UNSTABLE HANDLING	9-5
FAULTY LIGHTING OR SIGNALING SYSTEM	9-6
HEADLIGHT DOES NOT COME ON	9-6
HEADLIGHT BULB BURNT OUT	9-6
TAIL/BRAKE LIGHT DOES NOT COME ON	9-6
TAIL/BRAKE LIGHT BULB BURNT OUT	9-6
TURN SIGNAL DOES NOT COME ON	9-6
TURN SIGNAL BLINKS SLOWLY	9-6
TURN SIGNAL REMAINS LIT	9-6
TURN SIGNAL BLINKS QUICKLY	9-6
HORN DOES NOT SOUND	9-6

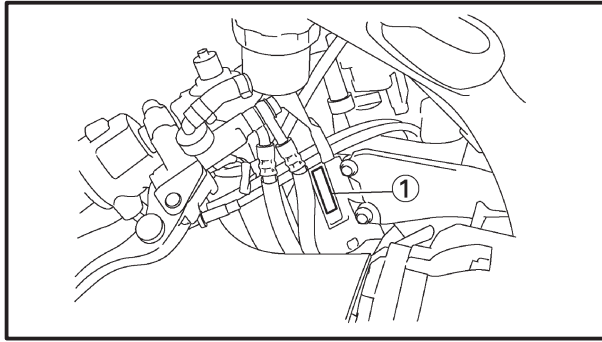

EAS00014

**GENERAL INFORMATION
MOTORCYCLE IDENTIFICATION**

EAS00017

VEHICLE IDENTIFICATION NUMBER

The vehicle identification number ① is stamped into the right side of the steering head pipe.

1

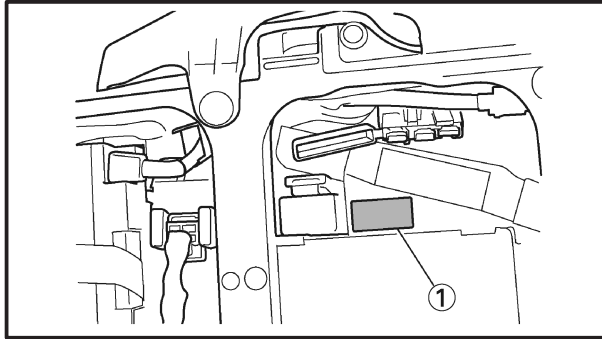

EAS00018

MODEL LABEL

The model label ① is affixed to the frame. This information will be needed to order spare parts.

EAS00896

FEATURES

OUTLINE OF FI SYSTEM

The main function of a fuel supply system is to provide fuel to the combustion chamber at the optimum air-fuel ratio in accordance with the engine operating conditions and the atmospheric temperature. In the conventional carburetor system, the air-fuel ratio of the mixture that is supplied to the combustion chamber is created by the volume of the intake air and the fuel that is metered by the jet used in the respective chamber.

Despite the same volume of intake air, the fuel volume requirement varies by the engine operating conditions, such as acceleration, deceleration, or operating under a heavy load. Carburetors that meter the fuel through the use of jets have been provided with various auxiliary devices, so that an optimum air-fuel ratio can be achieved to accommodate the constant changes in the operating conditions of the engine.

As the requirements for the engine to deliver more performance and cleaner exhaust gases increase, it becomes necessary to control the air-fuel ratio in a more precise and finely tuned manner. To accommodate this need, this model has adopted an electronically controlled fuel injection (FI) system, in place of the conventional carburetor system. This system can achieve an optimum air-fuel ratio required by the engine at all times by using a microprocessor that regulates the fuel injection volume according to the engine operating conditions detected by various sensors.

The adoption of the FI system has resulted in a highly precise fuel supply, improved engine response, better fuel economy, and reduced exhaust emissions. Furthermore, the air induction system (AI system) has been placed under computer control together with the FI system in order to realize cleaner exhaust gases.

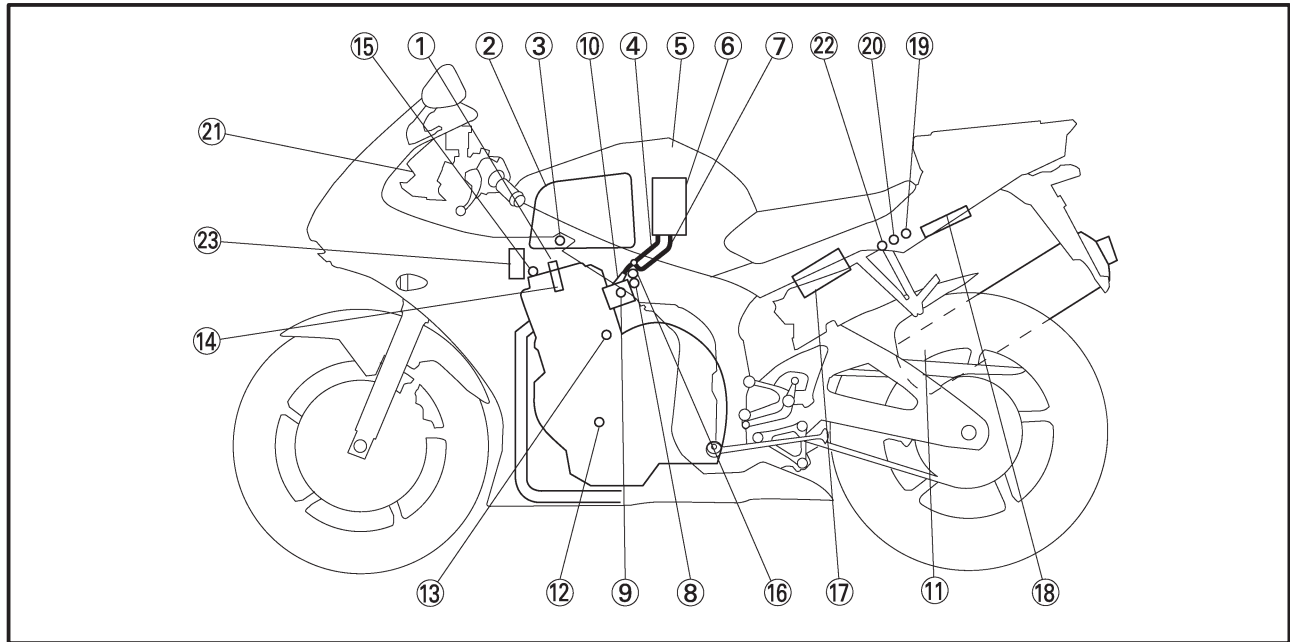

- | | | | |
|-----------------------------|------------------------------|----------------------------------|--------------------------------|
| ① Ignition coil | ⑧ Intake air pressure sensor | ⑭ Spark plug | ⑳ Engine trouble warning light |
| ② Air filter case | ⑨ Throttle position sensor | ⑮ Cylinder identification sensor | ㉑ Lean angle cut-off switch |
| ③ Intake temperature sensor | ⑩ Fuel injector | ⑯ Pressure regulator | ㉒ Air cut-off valve |
| ④ Fuel delivery hose | ⑪ Catalytic converter | ⑰ Battery | |
| ⑤ Fuel tank | ⑫ Crankshaft position sensor | ⑱ Atmospheric pressure sensor | |
| ⑥ Fuel pump | ⑬ Coolant temperature sensor | ㉓ Fuel injection system relay | |
| ⑦ Fuel return hose | | | |

EAS00897

FI SYSTEM

The fuel pump delivers fuel to the injector via the fuel filter. The pressure regulator maintains the fuel pressure that is applied to the injector at only 284 kPa (2.84 kg/cm²) higher than the intake manifold pressure. Accordingly, when the energizing signal from the ECU energizes the injector, the fuel passage opens, causing the fuel to be injected into the intake manifold only during the time the passage remains open. Therefore, the longer the length of time the injector is energized (injection duration), the greater the volume of fuel that is supplied. Conversely, the shorter the length of time the injector is energized (injection duration), the lesser the volume of fuel that is supplied.

The injection duration and the injection timing are controlled by the ECU. Signals that are input from the throttle position sensor, crankshaft position sensor, intake air pressure sensor, atmospheric pressure sensor, intake temperature sensor and coolant temperature sensor enable the ECU to determine the injection duration. The injection timing is determined through the signals from the crankshaft position sensor and the cylinder identification sensor. As a result, the volume of fuel that is required by the engine can be supplied at all times in accordance with the driving conditions.

Illustration is for reference only.

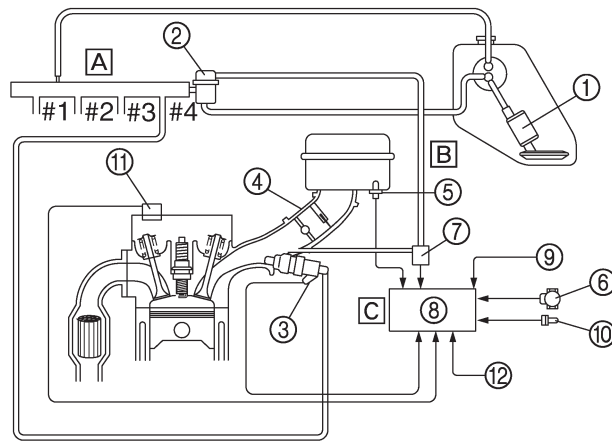

- | | | | |
|-----------------------------|-------------------------------|----------------------------------|-------------------------|
| ① Fuel pump | ⑥ Throttle position sensor | ⑩ Coolant temperature sensor | A Fuel system |
| ② Pressure regulator | ⑦ Intake air pressure sensor | ⑪ Cylinder identification sensor | B Air system |
| ③ Fuel injector | ⑧ ECU | ⑫ Crankshaft position sensor | C Control system |
| ④ Throttle body | ⑨ Atmospheric pressure sensor | | |
| ⑤ Intake temperature sensor | | | |

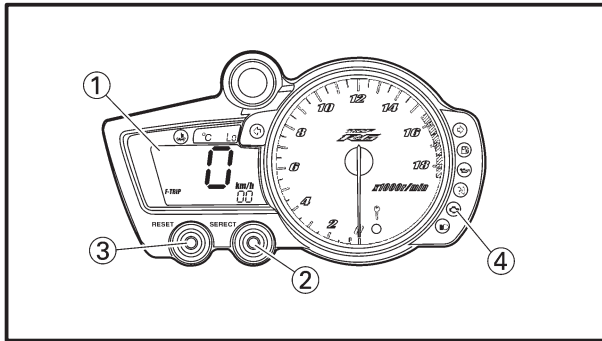

- ① Multi-function display
- ② “SELECT” button
- ③ “RESET” button
- ④ Engine trouble warning light

INSTRUMENT FUNCTION

Multi-function display

The multi-function display is equipped with the following:

- a speedometer (which shows the riding speed)
- an odometer (which shows the total distance traveled)
- two tripmeters (which show the distance traveled since they were last set to zero)
- a fuel reserve tripmeter (which shows the distance traveled since the fuel level warning light came on)
- a clock
- a self-diagnosis device
- a display brightness and engine speed warning light control mode

NOTE:

- Be sure to turn the key to “ON” before using the “SELECT” and “RESET” buttons.
- For the U.K. only: To switch the speedometer and odometer/tripmeter display between kilometers and miles, press the “SELECT” button and “RESET” button together for at least two seconds.

Odometer and tripmeter modes

Pushing the “SELECT” button switches the display between the odometer mode “ODO” and the tripmeter modes “TRIP 1” and “TRIP 2” in the following order:

ODO → TRIP 1 → TRIP 2 → ODO

If the fuel level warning light comes on, the odometer display will automatically change to the fuel reserve tripmeter mode “F-TRIP” and start counting the distance traveled from that point. In that case, pushing the “SELECT” button switches the display between the various tripmeter and odometer modes in the following order:

F-TRIP → TRIP 1 → TRIP 2 → ODO → F-TRIP

To reset a tripmeter, select it by pushing the “SELECT” button, and then push the “RESET” button for at least one second. If you do not reset the fuel reserve tripmeter manually, it will reset itself automatically and the display will return to the prior mode after refueling and traveling 5 km (3.1 mi).

Clock mode

Turn the key to “ON”.

To change the display to the clock mode, push the “SELECT” button for at least one second.

To change the display back to the prior mode, push the “SELECT” button.

To set the clock:

1. Push the “SELECT” button and “RESET” button together for at least two seconds.
2. When the hour digits start flashing, push the “RESET” button to set the hours.
3. Push the “SELECT” button, and the minute digits will start flashing.
4. Push the “RESET” button to set the minutes.
5. Push the “SELECT” button and then release it to start the clock.

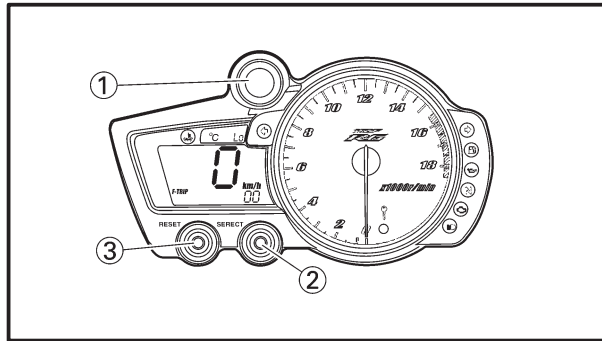

- ① Shift timing indicator light
- ② “SELECT” button
- ③ “RESET” button

Display brightness and shift timing indicator light control mode

This mode cycles through five control functions, allowing you to make the following settings in the order listed below.

1. Display brightness: This function allows you to adjust the brightness of the multi-function display to suit the outside lighting conditions.
2. Shift timing indicator light activity: This function allows you to choose whether or not the indicator light should be activated and whether it should blink or stay on when activated.
3. Shift timing indicator light activation: This function allows you to select the shift timing at which the indicator light will be activated.
4. Shift timing indicator light deactivation: This function allows you to select the engine speed at which the indicator light will be deactivated.
5. Shift timing indicator light brightness: This function allows you to adjust the brightness of the indicator light to suit your preference.

NOTE:

- To make any settings in this mode, you have to cycle through all of its functions. However, if the key is turned to “OFF” or engine is started before completing the procedure, only the settings made before the “SELECT” button was last pushed will be applied.
- In this mode, the multi-function display shows the current setting for each function (except the shift timing indicator light activity function).

To adjust the display brightness

1. Turn the key to “OFF”.
2. Push and hold the “SELECT” button.
3. Turn the key to “ON”, and then, after five seconds, release the “SELECT” button.
4. Push the “RESET” button to select the desired display brightness level.
5. Push the “SELECT” button to confirm the selected display brightness level. The control mode changes to the shift timing indicator light activity function.

To set the shift timing indicator light activity function

1. Push the “RESET” button to select one of the following indicator light activity settings:
 - a. The indicator light will stay on when activated. (This setting is selected when the indicator light stays on.)
 - b. The indicator light will flash when activated. (This setting is selected when the indicator light flashes four times per second.)
 - c. The indicator light is deactivated; in other words, it will not come on or flash. (This setting is selected when the indicator light flashes once every two seconds.)
2. Push the “SELECT” button to confirm the selected indicator light activity. The control mode changes to the shift timing indicator light activation function.

To set the shift timing indicator light activation function

NOTE: _____

- The indicator light activation function can be set between 10,000 and 16,000 r/min.
 - From 10,000 r/min to 12,000 r/min, the indicator light can be set in increments of 500 r/min.
 - From 12,000 r/min to 16,000 r/min, the indicator light can be set in increments of 200 r/min.
-

1. Push the “RESET” button to select the desired engine speed for activating the indicator light.
2. Push the “SELECT” button to confirm the selected engine speed.
The control mode changes to the shift timing indicator light deactivation function.

To set the shift timing indicator light deactivation function

NOTE: _____

- The indicator light deactivation function can be set between 7,000 and 12,000 r/min in increments of 500 r/min.
 - Be sure to set the deactivation function to a higher engine speed than for the activation function, otherwise the shift timing indicator light will remain deactivated.
-

1. Push the “RESET” button to select the desired engine speed for deactivating the indicator light.
2. Push the “SELECT” button to confirm the selected engine speed.
The control mode changes to the shift timing indicator light brightness function.

To adjust the shift timing indicator light brightness

1. Push the “RESET” button to select the desired indicator light brightness level.
2. Push the “SELECT” button to confirm the selected indicator light brightness level. The multi-function display will return to the odometer, tripmeter or clock mode.

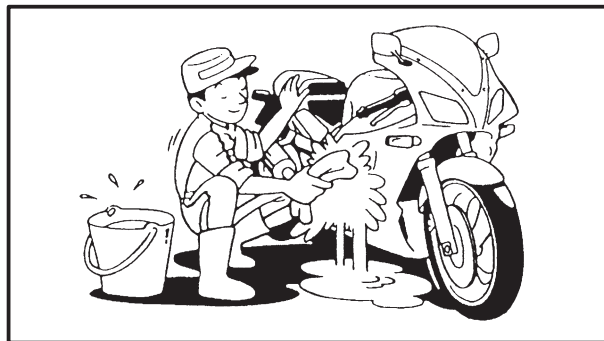

EAS00020

**IMPORTANT INFORMATION
PREPARATION FOR REMOVAL AND
DISASSEMBLY**

1. Before removal and disassembly, remove all dirt, mud, dust and foreign material.
2. Use only the proper tools and cleaning equipment.
Refer to the "SPECIAL TOOLS".
3. When disassembling, always keep mated parts together. This includes gears, cylinders, pistons and other parts that have been "mated" through normal wear. Mated parts must always be reused or replaced as an assembly.
4. During disassembly, clean all of the parts and place them in trays in the order of disassembly. This will speed up assembly and allow for the correct installation of all parts.
5. Keep all parts away from any source of fire.

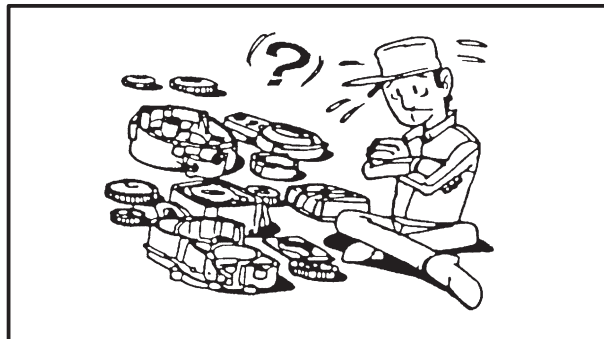

EAS00021

REPLACEMENT PARTS

Use only genuine Yamaha parts for all replacements. Use oil and grease recommended by Yamaha for all lubrication jobs. Other brands may be similar in function and appearance, but inferior in quality.

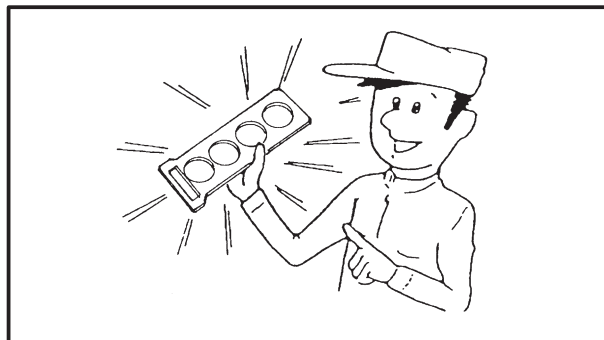

EAS00022

GASKETS, OIL SEALS AND O-RINGS

1. When overhauling the engine, replace all gaskets, seals and O-rings. All gasket surfaces, oil seal lips and O-rings must be cleaned.
2. During reassembly, properly oil all mating parts and bearings and lubricate the oil seal lips with grease.

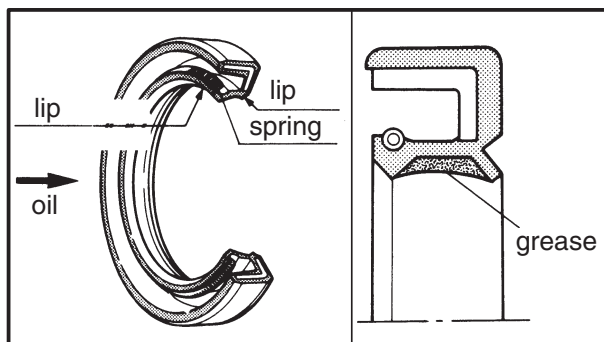

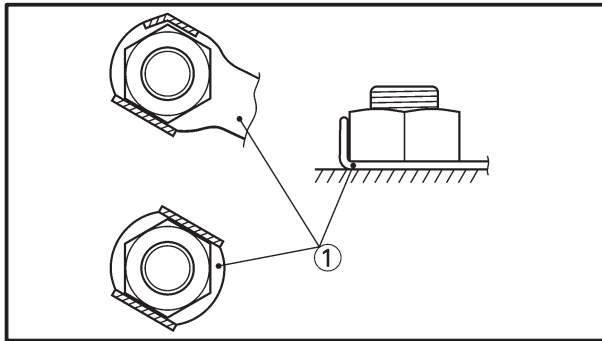

EAS00023

LOCK WASHERS/PLATES AND COTTER PINS

After removal, replace all lock washers/plates ① and cotter pins. After the bolt or nut has been tightened to specification, bend the lock tabs along a flat of the bolt or nut.

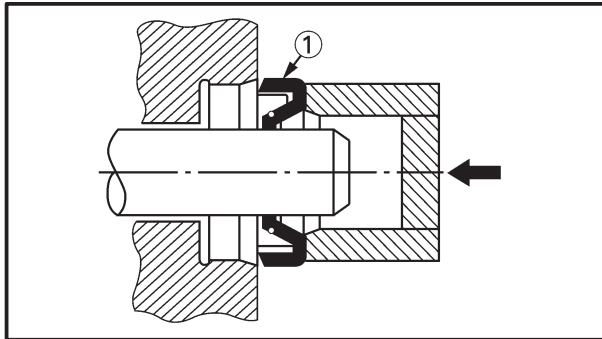

EAS00024

BEARINGS AND OIL SEALS

Install bearings and oil seals so that the manufacturer's marks or numbers are visible. When installing oil seals, lubricate the oil seal lips with a light coat of lithium-soap-based grease. Oil bearings liberally when installing, if appropriate.

① Oil seal

CAUTION: _____

Do not spin the bearing with compressed air because this will damage the bearing surfaces.

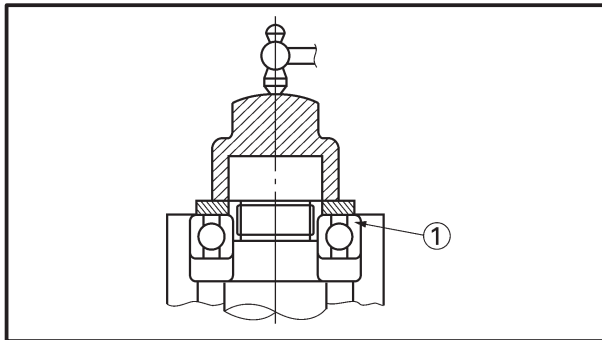

① Bearing

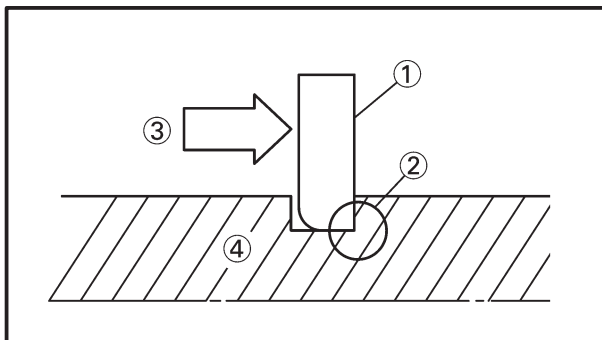

EAS00025

CIRCLIPS

Before reassembly, check all circlips carefully and replace damaged or distorted circlips. Always replace piston pin clips after one use. When installing a circlip ①, make sure the sharp-edged corner ② is positioned opposite the thrust ③ that the circlip receives.

④ Shaft

EAS00026

CHECKING THE CONNECTIONS

Check the leads, couplers, and connectors for stains, rust, moisture, etc.

1. Disconnect:

- lead
- coupler
- connector

2. Check:

- lead
- coupler
- connector

Moisture → Dry with an air blower.

Rust/stains → Connect and disconnect several times.

3. Check:

- all connections

Loose connection → Connect properly.

NOTE: _____

If the pin ① on the terminal is flattened, bend it up.

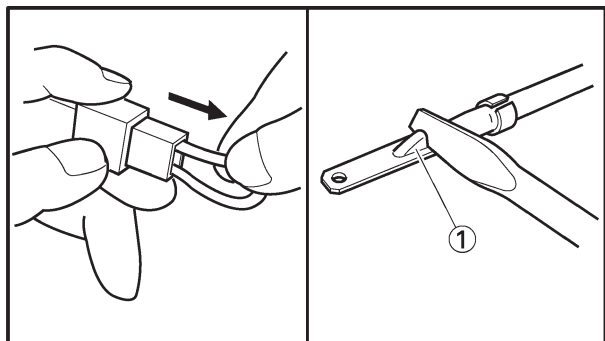
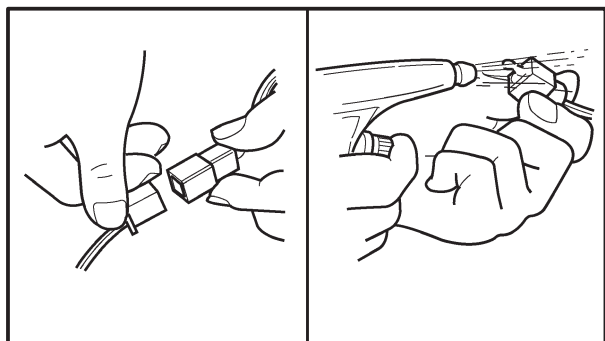

4. Connect:

- lead
- coupler
- connector

NOTE: _____

Make sure all connections are tight.

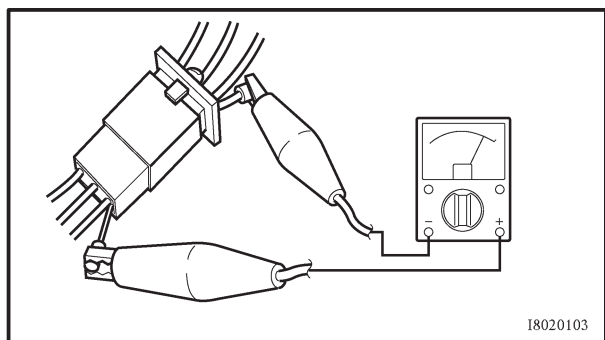

I8020103

5. Check:

- continuity
(with the pocket tester)

	<p>Pocket tester 90890-03112, YU-3112</p>
---	--

NOTE: _____

- If there is no continuity, clean the terminals.
- When checking the wire harness, perform steps (1) to (3).
- As a quick remedy, use a contact revitalizer available at most part stores.

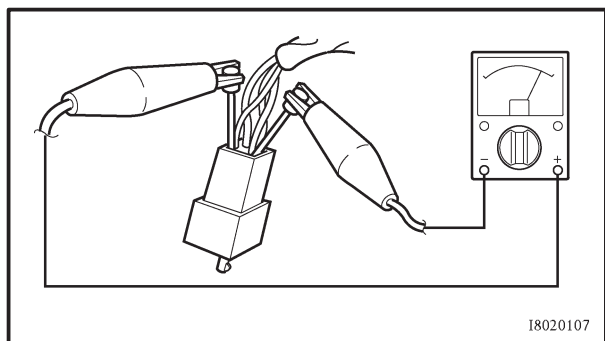

I8020107



EAS00027

SPECIAL TOOLS

The following special tools are necessary for complete and accurate tune-up and assembly. Use only the appropriate special tools as this will help prevent damage caused by the use of inappropriate tools or improvised techniques. Special tools, part numbers or both may differ depending on the country. When placing an order, refer to the list provided below to avoid any mistakes.

NOTE:

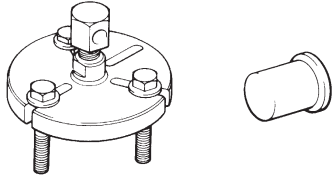
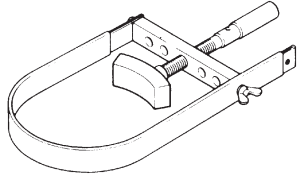
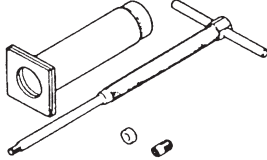
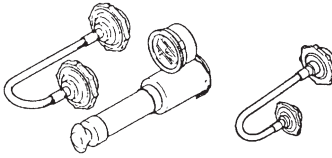
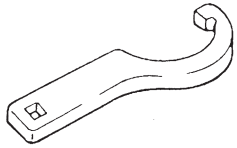
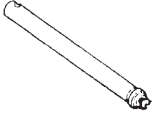
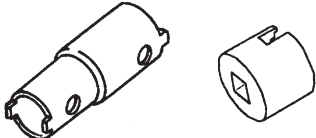

- For U.S.A. and Canada, use part number starting with "YM-", "YU-", or "ACC-".
- For others, use part number starting with "90890-".

Tool No.	Tool name/Function	Illustration
Flywheel puller 90890-01362 YU-33270-B Adapter 90890-04089 YM-33282	Flywheel puller Adapter This tool is used to remove the generator rotor.	
90890-01701 YS-01880-A	Sheave holder This tool is used to hold the generator rotor when removing or installing the generator rotor bolt or pickup coil rotor bolt.	
90890-01304 YU-01304	Piston pin puller This tool is used to remove the piston pins.	
Radiator cap tester 90890-01325 YU-24460-01 Adapter 90890-01352 YU-33984	Radiator cap tester Adapter These tools are used to check the cooling system.	
90890-01403 YU-33975	Steering nut wrench This tool is used to loosen or tighten the steering stem ring nuts.	
90890-01473	Damper rod holder This tool is used to hold the damper rod assembly when loosening or tightening the damper rod assembly bolt.	
Pivot shaft wrench 90890-01471 YM-01471 Pivot shaft wrench adapter 90890-01476	Pivot shaft wrench Pivot shaft wrench adapter This tool is used to loosen or tighten the pivot adjust bolt and engine mount adjust bolt.	

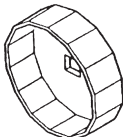
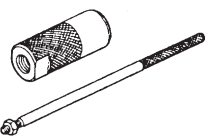
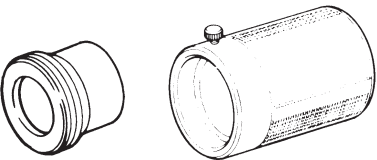
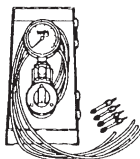
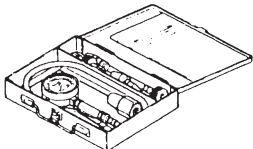
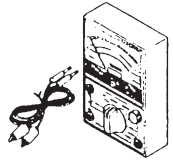
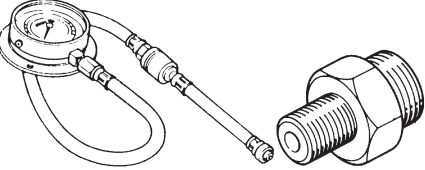
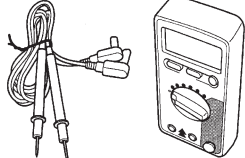
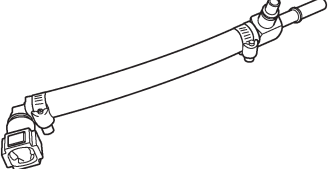
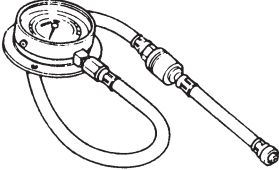

Tool No.	Tool name/Function	Illustration
90890-01426 YU-38411	Oil filter wrench This tool is needed to loosen or tighten the oil filter cartridge.	
Rod puller 90890-01437 YM-01437 Rod puller attachment 90890-01436	Rod puller Rod puller attachment These tools are used to pull up the front fork damper rod.	
Fork seal driver 90890-01367 YM-33963 Fork seal driver attachment 90890-01374 YM-8020-A	Fork seal driver weight Fork seal driver attachment This tool is used to install the front fork's oil seal and dust seal.	
Vacuum gauge 90890-03094 YU-08030	Vacuum gauge This gauge is used to synchronize the carburetors.	
Compression gauge 90890-03081 YU-33223 Adapter 90890-04136	Compression gauge Adapter These tools are used to measure engine compression.	
90890-03112 YU-3112	Pocket tester This tool is used to check the electrical system.	
Oil pressure gauge 90890-03153 YU-03153 Adapter 90890-03139	Oil pressure gauge Adapter These tools are used to measure engine oil pressure.	
90890-03174	Digital circuit tester This tool is used to check the electrical system.	
90890-03176 YM-03176	Fuel pressure adapter This tool is needed to measure fuel pressure.	
90890-03153 YU-03153	Pressure gauge This tool used is to measure fuel pressure.	

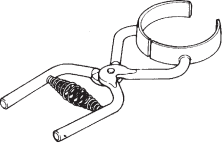
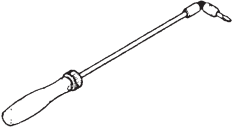
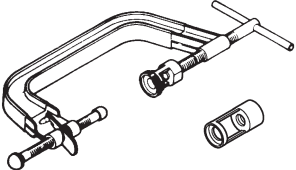
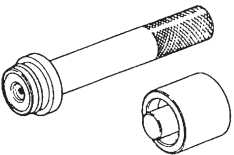
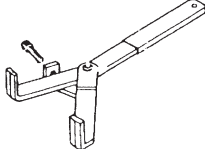
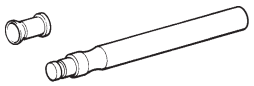

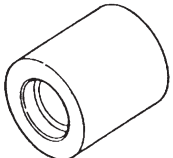
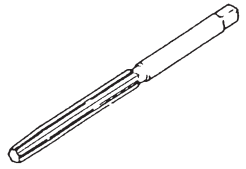
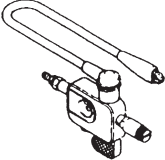
Tool No.	Tool name/Function	Illustration
90890-04044 YM-04044	Piston ring compressor This tool is used to compress piston rings when installing the cylinder.	
90890-03158	Carburetor angle driver This tool is used to turn the pilot screw when adjusting the engine idling speed.	
Valve spring compressor 90890-04019 YM-04019 Attachment 90890-04108 YM-01253	Valve spring compressor Attachment These tools are used to remove or install the valve assemblies.	
Middle driven shaft bearing driver 90890-04058 YM-4058 Mechanical seal installer 90890-04078 YM-33221	Middle driven shaft bearing driver Mechanical seal installer These tools are used to install the water pump seal.	
90890-04086 YM-91042	Clutch holding tool This tool is used to hold the clutch boss when removing or installing the clutch boss nut.	
90890-04101	Valve lifter This tool is needed to remove and install the valve lifter.	
90890-04111	Valve guide remover ($\phi 4$) This tool is used to remove or install the valve guides.	
90890-04112	Valve guide installer ($\phi 4$) This tool is used to install the valve guides.	
90890-04113 YM-04113	Valve guide reamer ($\phi 4$) This tool is used to rebores the new valve guides.	
90890-06754 YM-34487	Ignition checker This tool is used to check the ignition system components.	

SPECIAL TOOLS**GEN
INFO**

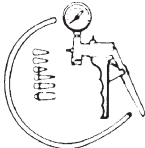
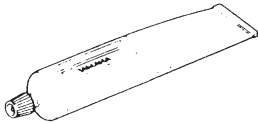
Tool No.	Tool name/Function	Illustration
90890-06756 YB-35956	Vacuum/pressure pump gauge set This tool used to measure the vacuum pressure.	
90890-85505 ACC-11001-05-01	Yamaha bond No. 1215 This bond is used to seal two mating surfaces (e.g., crankcase mating surfaces).	



SPECIFICATIONS

GENERAL SPECIFICATIONS

Item	Standard	Limit
Model code	5SL3 (USA except for CAL) 5SL4 (CAL) 5SL7 (USA except for CAL) 5SL8 (CAL)	...
Dimensions		
Overall length	2,025 mm (79.7 in)	...
Overall width	690 mm (27.2 in)	...
Overall height	1,090 mm (42.9 in)	...
Seat height	820 mm (32.3 in)	...
Wheelbase	1,380 mm (54.3 in)	...
Minimum ground clearance	135 mm (5.3 in)	...
Minimum turning radius	3,400 mm (133.9 in)	...
Weight		
Wet (with oil and a full fuel tank)	182 kg (401 lb) (USA except for CAL) 183 kg (404 lb) (CAL)	...
Maximum load (except motorcycle)	193 kg (426 lb) (USA except for CAL) 192 kg (423 lb) (CAL)	...

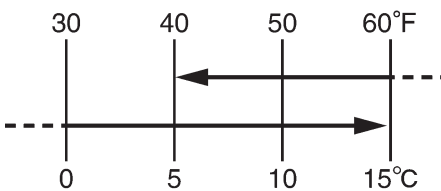

ENGINE SPECIFICATIONS

Item	Standard	Limit
Engine Engine type Displacement Cylinder arrangement Bore × stroke Compression ratio Engine idling speed Vacuum pressure at engine idling speed Standard compression pressure (at sea level)	Liquid-cooled, 4-stroke, DOHC 600 cm ³ (36.61 cu.in) Forward-inclined parallel 4-cylinder 65.5 × 44.5 mm (2.58 × 1.75 in) 12.4 : 1 1,250 ~ 1,350 r/min 24 kPa (180 mmHg, 7.0872inHg) 1,550 kPa (15.50 kg/cm ² , 15.50 bar, 220.46 psi) at 400 r/min
Fuel Recommended fuel Fuel tank capacity Total (including reserve) Reserve only	Premium unleaded gasoline only 17 L (3.74 Imp gal, 4.49 US gal) 3.5 L (0.77 Imp gal, 0.92 US gal)
Engine oil Lubrication system Recommended oil  Quantity Total amount Without oil filter cartridge replacement With oil filter cartridge replacement Oil pressure Engine oil temperature Relief valve opening pressure	Wet sump At 5°C (40°F) or higher Yamalube 4 (20W40) or SAE 20W40 type SE motor oil At 15°C (60°F) or lower Yamalube 4 (10W30) or SAE 10W30 type SE motor oil 3.4 L (2.99 Imp qt, 3.59 US qt) 2.4 L (2.11 Imp qt, 2.54 US qt) 2.6 L (2.29 Imp qt, 2.75 US qt) 240 kPa at 6,600 r/min (2.4 kg/cm ² at 6,600 r/min) (2.4 bar at 6,600 r/min) (34.1 psi at 6,600 r/min) 96°C (205°F) 450 ~ 550 kPa (4.5 ~ 5.5 kg/cm ² , 4.5 ~ 5.5 bar, 65.3 ~ 79.8 psi)

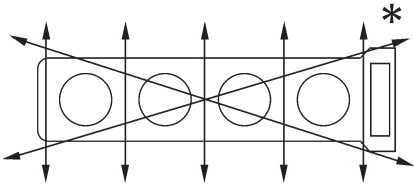

Item	Standard	Limit
Oil filter Oil filter type Bypass valve opening pressure	Formed 80 ~ 120 kPa (0.8 ~ 1.2 kg/cm ² , 0.8 ~ 1.2 bar, 11.6 ~ 17.4 psi)
Oil pump Oil pump type Inner-rotor-to-outer-rotor-tip clearance Outer-rotor-to-oil-pump-housing clearance	Trochoid 0.03 ~ 0.09 mm (0.0012 ~ 0.0035 in) 0.03 ~ 0.08 mm (0.0012 ~ 0.0031 in)	... 0.15 mm (0.0059 in) 0.15 mm (0.0059 in)
Cooling system Radiator capacity Radiator cap opening pressure Radiator core Width Height Depth Coolant reservoir Capacity Water pump Water pump type Reduction ratio Max. impeller shaft tilt	2.15 L (1.89 Imp qt, 2.27 US qt) 110 ~ 140 kPa (1.1 ~ 1.4 kg/cm ² , 1.1 ~ 1.4 bar, 16.0 ~ 20.3 psi) 320 mm (12.6 in) 258 mm (10.2 in) 24 mm (0.94 in) 0.44 L (0.39 Imp qt, 0.47 US qt) Single suction centrifugal pump 86/44 × 31/31 (1.955) 0.15 mm (0.006 in)
Starting system type	Electric starter	
Electric fuel injection Type Manufacturer	INP-250/4 NIPPON INJECTOR
Spark plugs Model (manufacturer) × quantity Spark plug gap	CR9EK or CR10EK (NGK) × 4 0.6 ~ 0.7 mm (0.0236 ~ 0.0276 in)
Cylinder head Volume Max. warpage 	10.3 ~ 10.9 cm ³ (0.63 ~ 0.67 cu.in) 0.05 mm (0.002 in)



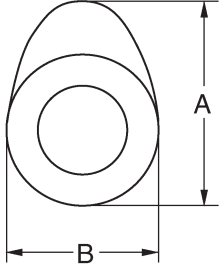
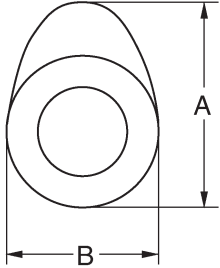
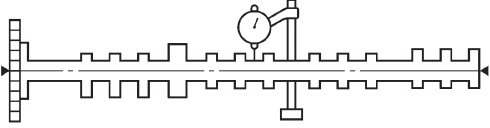

Item	Standard	Limit
<p>Camshafts Drive system Camshaft cap inside diameter Camshaft journal diameter Camshaft-journal-to-camshaft-cap clearance Intake camshaft lobe dimensions</p>	<p>Chain drive (right) 23.008 ~ 23.029 mm (0.9058 ~ 0.9067 in) 22.967 ~ 22.980 mm (0.9042 ~ 0.9047 in) 0.028 ~ 0.062 mm (0.0011 ~ 0.0024 in)</p>	<p>••• ••• ••• 0.08 mm (0.0031 in)</p>
		
<p>Measurement A</p>	<p>33.45 ~ 33.55 mm (1.317 ~ 1.321 in)</p>	<p>33.40 mm (1.315 in)</p>
<p>Measurement B</p>	<p>25.12 ~ 25.22 mm (0.989 ~ 0.993 in)</p>	<p>25.07 mm (0.987 in)</p>
<p>Exhaust camshaft lobe dimensions</p>		
		
<p>Measurement A</p>	<p>32.55 ~ 32.65 mm (1.282 ~ 1.285 in)</p>	<p>32.50 mm (1.280 in)</p>
<p>Measurement B</p>	<p>25.07 ~ 25.17 mm (0.987 ~ 0.991 in)</p>	<p>25.02 mm (0.985 in)</p>
<p>Max. camshaft runout</p>	<p>•••</p>	<p>0.06 mm (0.0024 in)</p>
		

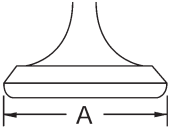
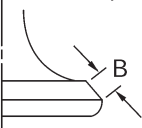
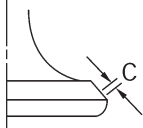
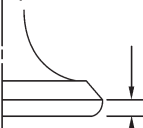
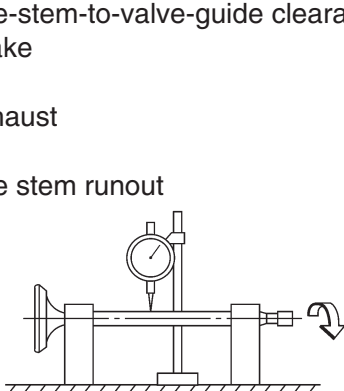

Item	Standard	Limit
Timing chain		
Model/number of links	RH2015/120	•••
Tensioning system	Automatic	•••
Valves, valve seats, valve guides		
Valve clearance (cold)		
Intake	0.13 ~ 0.20 mm (0.0051 ~ 0.0079 in)	•••
Exhaust	0.23 ~ 0.30 mm (0.0091 ~ 0.0118 in)	•••
Valve dimensions		
		
		
Head Diameter	Face Width	Seat Width
		Margin Thickness
Valve head diameter A		
Intake	24.9 ~ 25.1 mm (0.9803 ~ 0.9882 in)	•••
Exhaust	21.9 ~ 22.1 mm (0.8622 ~ 0.8701 in)	•••
Valve face width B		
Intake	1.14 ~ 1.98 mm (0.0449 ~ 0.0780 in)	•••
Exhaust	1.14 ~ 1.98 mm (0.0449 ~ 0.0780 in)	•••
Valve seat width C		
Intake	0.9 ~ 1.1 mm (0.0354 ~ 0.0433 in)	1.6 mm (0.06 in)
Exhaust	0.9 ~ 1.1 mm (0.0354 ~ 0.0433 in)	1.6 mm (0.06 in)
Valve margin thickness D		
Intake	0.6 ~ 0.8 mm (0.0236 ~ 0.0315 in)	0.5 mm (0.02 in)
Exhaust	0.6 ~ 0.8 mm (0.0236 ~ 0.0315 in)	0.5 mm (0.02 in)
Valve stem diameter		
Intake	3.975 ~ 3.990 mm (0.1565 ~ 0.1571 in)	3.95 mm (0.1555 in)
Exhaust	3.960 ~ 3.975 mm (0.1559 ~ 0.1565 in)	3.935 mm (0.1549 in)
Valve guide inside diameter		
Intake	4.000 ~ 4.012 mm (0.1575 ~ 0.1580 in)	4.042 mm (0.1591 in)
Exhaust	4.000 ~ 4.012 mm (0.1575 ~ 0.1580 in)	4.042 mm (0.1591 in)
Valve-stem-to-valve-guide clearance		
Intake	0.010 ~ 0.037 mm (0.0004 ~ 0.0015 in)	0.08 mm (0.0031 in)
Exhaust	0.025 ~ 0.052 mm (0.0010 ~ 0.0020 in)	0.10 mm (0.0039 in)
Valve stem runout		
	•••	0.04 mm (0.0016 in)
		
Valve seat width		
Intake	0.9 ~ 1.1 mm (0.0354 ~ 0.0433 in)	1.6 mm (0.06 in)
Exhaust	0.9 ~ 1.1 mm (0.0354 ~ 0.0433 in)	1.6 mm (0.06 in)

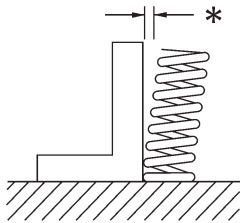

Item	Standard	Limit
Valve springs		
Free length		
Intake (inner)	35.7 mm (1.41 in)	33.9 mm (1.33 in)
(outer)	40.3 mm (1.59 in)	38.3 mm (1.50 in)
Exhaust	41.7 mm (1.64 in)	39.6 mm (1.56 in)
Installed length (valve closed)		
Intake (inner)	30 mm (1.18 in)	•••
(outer)	32.5 mm (1.28 in)	•••
Exhaust	36.1 mm (1.42 in)	•••
Compressed spring force		
(installed)		
Intake (inner)	61.5 ~ 70.7 N (6.27 ~ 7.21 kg, 13.83 ~ 15.89 lb)	•••
(outer)	139.1 ~ 160.1 N (14.18 ~ 16.33 kg, 31.27 ~ 35.99 lb)	•••
Exhaust	160 ~ 184 N (16.32 ~ 18.76 kg, 35.97 ~ 41.36 lb)	•••
Spring tilt		
		
Intake (inner)	•••	2.5°/1.6 mm (0.06 in)
(outer)	•••	2.5°/1.8 mm (0.07 in)
Exhaust	•••	2.5°/1.8 mm (0.07 in)
Winding direction (top view)		
Intake (inner)	Counter clockwise	•••
(outer)	Clockwise	•••
Exhaust	Clockwise	•••
		
Cylinders		
Cylinder arrangement	Forward-inclined, parallel 4-cylinder	•••
Bore × stroke	65.5 mm × 44.5 mm (2.58 × 1.75 in)	•••
Compression ratio	12.4 : 1	•••
Bore	65.50 ~ 65.51 mm (2.5787 ~ 2.5791 in)	•••
Max. out-of-round	•••	0.05 mm (0.002 in)